

# GE Sensing

## Features

### NTC Type HM

- Low cost, solid state temperature sensor
- Point matched at 77°F (25°C) to  $\pm 5\%$  or  $\pm 10\%$
- Suitable for use over range of -112°F to 302°F (-80°C to 150°C)
- High sensitivity greater than  $-4\%/^{\circ}\text{C}$  at 77°F (25°C)
- Suitable for temperature measurement, control and compensation
- Palladium Silver contacts suitable for soldering or conductive epoxy bonding
- Sizes from 0.025 in x 0.025 in to 0.085 in x 0.085 in (0.63 mm x 0.63 mm to 2.15 mm x 2.15 mm) available
- Not suitable for immersion in fluids or high humidity

### NTC Type NDU

- Designed for accurate temperature measurement, control and compensation
- Tight tolerances on resistance and B value
- Operation up to 311°F (155°C) with excellent stability
- Small body size
- Fast response
- Suitable for automotive, HVAC and white goods applications

---

# NTC Leadless Chips

## Thermometrics Thermistors

NTC Leadless Chips are a Thermometrics product. Thermometrics has joined other GE high-technology sensing businesses under a new name—GE Industrial, Sensing.



# Type HM Specifications

Leadless chip thermistor

## Description

Top and bottom electrode, uncoated chip thermistors without leads.

Select appropriate part number below for resistance and temperature tolerance desired

R25°C	Material System	Width "W" in (mm)	Length "L" in (mm)	Thick "T" in (mm)	R25° ± 5%	R25° ± 10%
2252	F	0.070 (1.778)	0.070 (1.778)	0.010 (0.254)	HM70NF232J	HM70NF232K
2252	F	0.085 (2.159)	0.085 (2.159)	0.015 (0.380)	HM85NF232J	HM85NF232K
3000	F	0.060 (1.523)	0.060 (1.523)	0.010 (0.254)	HM60NF302J	HM60NF302K
3000	F	0.075 (1.904)	0.075 (1.904)	0.015 (0.380)	HM75NF302J	HM75NF302K
5000	F	0.050 (1.27)	0.050 (1.27)	0.010 (0.254)	HM50NF502J	HM50NF502K
5000	F	0.060 (1.523)	0.060 (1.523)	0.015 (0.380)	HM60NF502J	HM60NF502K
10000	F	0.035 (0.889)	0.035 (0.889)	0.010 (0.254)	HM35NF103J	HM35NF103K
10000	F	0.040 (1.016)	0.045 (1.1429)	0.015 (0.380)	HM40NF103J	HM40NF103K
10000	Y	0.045 (1.1429)	0.045 (1.1429)	0.010 (0.254)	HM45NY103J	HM45NY103K
10000	Y	0.055 (1.397)	0.055 (1.397)	0.015 (0.380)	HM55NY103J	HM55NY103K
30000	H	0.025 (0.635)	0.025 (0.635)	0.010 (0.254)	HM25NH303J	HM25NH303K
30000	H	0.030 (0.7619)	0.035 (0.889)	0.015 (0.380)	HM30NH303J	HM30NH303K
100000	Y	0.030 (0.7619)	0.030 (0.7619)	0.010 (0.254)	HM30NY104J	HM30NY104K
100000	Y	0.035 (0.889)	0.035 (0.889)	0.015 (0.380)	HM35NY104J	HM35NY104K

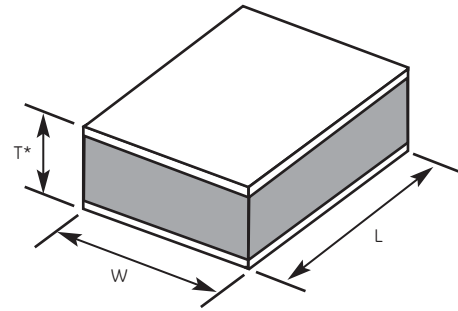

NTC Type HM dimensions

## Options

Consult GE for availability of options:

- Other resistance values in the range of 100 Ω to 100 kΩ
- Other tolerances
- Other reference temperature
- Gold electrodes suitable for wire bonding
- Other sizes

## Data

**Thermal and Electrical Properties:**

- Dissipation constant: (still air) 7 to 15 mW/K
- Thermal time constant: (still air) 10 to 45 seconds
- The thermal time constant and dissipation constant values are dependent upon the method of mounting. The above values represent the range of smallest to largest HM thermistor chips when soldering to an aluminum substrate 0.025 in (0.635 mm) thick using 2% silver solder.

# Type NDU Specifications

Leadless chip thermistor

## Description

A range of leadless chip thermistors.

## Options

- Other resistance values in the range shown; e.g. code NDU152C2R1 for 1500 Ω ±1% at 77°F (25°C)
- Reference temperature in the range of 32°F (0°C) up to the maximum operating temperature
- Resistance value outside the ranges shown with modified dimensions

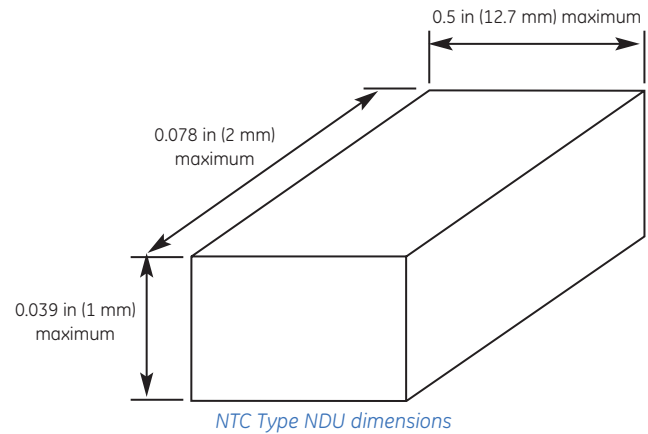

## Data

- Minimum operating temperature: -40°F (-40°C)
- Maximum operating temperature: See table below
- Resistance tolerance: ±3% or greater
- Electrode: Thick film silver
- Packaging/MOQ: 1000/box

R25 Ω	Material System	B 25/85 K	Maximum temp. °F (°C)	Code R25 ± 3%	Code R25 ± 5%	Code R25 ± 10%
1000	2	3540 ± 1%	257 (125)	NDU102C2R3	NDU102C2R5	NDU102C2R10
2000	2	3540 ± 1%	257 (125)	NDU202C2R3	NDU202C2R5	NDU202C2R10
5000	2	3540 ± 1%	257 (125)	NDU502C2R3	NDU502C2R5	NDU502C2R10
1000	2A	3627 ± 1%	257 (125)	NDU102C2AR3	NDU102C2AR5	NDU102C2AR10
2000	2A	3627 ± 1%	257 (125)	NDU202C2AR3	NDU202C2AR5	NDU202C2AR10
5000	2A	3627 ± 1%	257 (125)	NDU502C2AR3	NDU502C2AR5	NDU502C2AR10
2700	1	3977± 0.75%	311 (155)	NDU272C1R3	NDU272C1R5	NDU272C1R10
5000	1	3977± 0.75%	311 (155)	NDU502C1R3	NDU502C1R5	NDU502C1R10
10000	1	3977± 0.75%	311 (155)	NDU103C1R3	NDU103C1R5	NDU103C1R10
30000	1	3977± 0.75%	311 (155)	NDU303C1R3	NDU303C1R5	NDU303C1R10
50000	1	3977± 0.75%	311 (155)	NDU503C1R3	NDU503C1R5	NDU503C1R10
2700	3	3960± 1%	311 (155)	NDU272C3R3	NDU272C3R5	NDU272C3R10
5000	3	3960± 1%	311 (155)	NDU502C3R3	NDU502C3R5	NDU502C3R10
10000	3	3960± 1%	311 (155)	NDU103C3R3	NDU103C3R5	NDU103C3R10
30000	3	3960± 1%	311 (155)	NDU303C3R3	NDU303C3R5	NDU303C3R10
50000	3	3960± 1%	311 (155)	NDU503C3R3	NDU503C3R5	NDU503C3R10
10000	4	3435 ± 1%	230 (110)	NDU103C4R3	NDU103C4R5	NDU103C4R10
30000	4	3435 ± 1%	230 (110)	NDU303C4R3	NDU303C4R5	NDU303C4R10
50000	4	3435 ± 1%	230 (110)	NDU503C4R3	NDU503C4R5	NDU503C4R10

See separate tables for resistance - temperature data

GE  
Sensing



©2006 GE. All rights reserved.  
920-323A

All specifications are subject to change for product improvement without notice.  
GE® is a registered trademark of General Electric Co. Other company or product  
names mentioned in this document may be trademarks or registered trademarks  
of their respective companies, which are not affiliated with GE.

[www.gesensing.com](http://www.gesensing.com)