



DigitalFlow™ GM868

Panametrics Multipurpose Ultrasonic Gas Flowmeter

Startup Guide (1 and 2-Channel)



GE
Sensing & Inspection Technologies

DigitalFlow™ GM868

Panametrics Multipurpose Ultrasonic Gas Flowmeter



Startup Guide (1 and 2-Channel)

910-193UE1

March 2008

The *DigitalFlow GM868* is a GE Panametrics product. GE Panametrics has joined other GE high-technology businesses under a new name—GE Sensing & Inspection Technologies.



Warranty

Each instrument manufactured by GE Sensing, Inc. is warranted to be free from defects in material and workmanship. Liability under this warranty is limited to restoring the instrument to normal operation or replacing the instrument, at the sole discretion of GE. Fuses and batteries are specifically excluded from any liability. This warranty is effective from the date of delivery to the original purchaser. If GE determines that the equipment was defective, the warranty period is:

- one year for general electronic failures of the instrument
- one year for mechanical failures of the sensor

If GE determines that the equipment was damaged by misuse, improper installation, the use of unauthorized replacement parts, or operating conditions outside the guidelines specified by GE, the repairs are not covered under this warranty.

The warranties set forth herein are exclusive and are in lieu of all other warranties whether statutory, express or implied (including warranties of merchantability and fitness for a particular purpose, and warranties arising from course of dealing or usage or trade).

Return Policy

If a GE Sensing, Inc. instrument malfunctions within the warranty period, the following procedure must be completed:

1. Notify GE, giving full details of the problem, and provide the model number and serial number of the instrument. If the nature of the problem indicates the need for factory service, GE will issue a RETURN AUTHORIZATION number (RA), and shipping instructions for the return of the instrument to a service center will be provided.
2. If GE instructs you to send your instrument to a service center, it must be shipped prepaid to the authorized repair station indicated in the shipping instructions.
3. Upon receipt, GE will evaluate the instrument to determine the cause of the malfunction.

Then, one of the following courses of action will then be taken:

- If the damage is covered under the terms of the warranty, the instrument will be repaired at no cost to the owner and returned.
- If GE determines that the damage is not covered under the terms of the warranty, or if the warranty has expired, an estimate for the cost of the repairs at standard rates will be provided. Upon receipt of the owner's approval to proceed, the instrument will be repaired and returned.

Table of Contents

Chapter 1: Installation

Introduction.....	1-1
Unpacking	1-1
Site Considerations.....	1-2
Electronics Console Location.....	1-2
Flowcell Location.....	1-2
Transducer Location.....	1-2
Cable Lengths.....	1-3
Temperature and Pressure Transmitters.....	1-3
Transducer Cables.....	1-3
Installing a Flowcell.....	1-3
Installing Temperature and Pressure Transmitters.....	1-5
Mounting the GM868 Electronic Console.....	1-6
Making the Electrical Connections.....	1-6
Wiring the Line Power.....	1-7
Wiring the Transducers.....	1-9
Wiring the 0/4-20 mA Analog Outputs.....	1-10
Wiring the Serial Port.....	1-10
Wiring an Alarms Option Card.....	1-14
Wiring a 0/4-20 mA Analog Inputs Option Card.....	1-15
Wiring a Totalizer/Frequency Outputs Option Card.....	1-16
Wiring an RTD Inputs Option Card.....	1-17
Wiring a 0/4-20 mA Analog Outputs Option Card.....	1-17

Chapter 2: Initial Setup

Introduction.....	2-1
Navigating Through the User Program.....	2-1
Accessing the User Program.....	2-2
Activating a Channel.....	2-3
1-Channel Meter.....	2-3
2-Channel Meter.....	2-3
1 and 2-Channel Meters.....	2-3
Entering System Data for a Channel.....	2-4
1-Channel Meter.....	2-4
2-Channel Meter.....	2-5
1 and 2-Channel Meters.....	2-5
Entering Pipe Data.....	2-7
Special Transducers.....	2-7
Pipe OD.....	2-7
Pipe Wall.....	2-7
Path Length.....	2-8
Axial Length.....	2-8
Fluid Type.....	2-8
Reynolds Correction.....	2-8
Calibration Factor.....	2-8

Table of Contents (cont.)

Chapter 3: Operation

Introduction	3-1
Powering Up	3-2
Using the Display	3-3
Taking Measurements	3-5
Foundation Fieldbus Communications	3-6

Chapter 4: Specifications

General	4-1
Fluid Types	4-1
Electrical	4-2
Operational	4-4
Wetted Transducer	4-4
Flowcell	4-5
Spoolpiece	4-5
Cold Tap	4-5
Pipe Size & Materials	4-5

Appendix A: CE Mark Compliance

Introduction	A-1
Wiring	A-1
External Grounding	A-1

Appendix B: Data Records

Option Cards Installed	B-1
Initial Setup Data	B-2

Appendix C: Optional Enclosures

Introduction	C-1
Rack Mount Enclosure	C-1
Rack Mount Wiring	C-1
Rack Mount Front Panel	C-2

Appendix D: Measuring P and L Dimensions

Introduction	D-1
Measuring P and L Distances	D-1

Chapter 1

Installation

- Introduction..... 1-1
- Unpacking 1-1
- Site Considerations 1-2
- Installing a Flowcell..... 1-3
- Installing Temperature and Pressure Transmitters..... 1-5
- Mounting the GM868 Electronic Console 1-6
- Making the Electrical Connections..... 1-6

Introduction

To ensure safe and reliable operation of the Model GM868 Ultrasonic Flowmeter for Gas, the system must be installed in accordance with the guidelines established by GE's engineers. Those guidelines, which are explained in detail in this chapter, include the following specific topics:

- Unpacking the Model GM868 system
- Selecting a suitable site for the electronics console and the flowcell/transducers
- Installing a flowcell
- Installing temperature and pressure transmitters
- Installing the Electronics Console
- Wiring the Electronics Console.

!WARNING!

The Model GM868 flowmeter can measure the flow rate of many gases, some of which are potentially hazardous. In such cases, the importance of proper safety practices cannot be overemphasized.

Be sure to follow all applicable local safety codes and regulations for installing electrical equipment and working with hazardous gases or flow conditions. Consult company safety personnel or local safety authorities to verify the safety of any procedure or practice.

ATTENTION EUROPEAN CUSTOMERS!

In order to meet CE Mark requirements, all wiring connections must be made in accordance with the instructions in Appendix A, *CE Mark Compliance*.

Unpacking

Carefully remove the electronics console, the transducers, and the cables from the shipping containers. Before discarding any of the packing materials, account for all components and documentation listed on the packing slip. The discarding of an important item along with the packing materials is all too common. If anything is missing or damaged, contact the factory immediately for assistance.

Site Considerations

Because the relative physical locations of the flowcell and the Model GM868 electronics console are important, use the guidelines given in this section to plan the Model GM868 system installation.

Electronics Console Location

The standard Model GM868 electronics enclosure is a Type-4X weather-resistant, dust-tight, indoor/outdoor type. Typically, the electronics console is mounted in a meter shed. When choosing a mounting site, make sure that the location permits easy access to the console for programming, testing, and servicing.

Note: *For compliance with the European Union's Low Voltage Directive (73/23/EEC), this unit requires an external power disconnect device such as a switch or circuit breaker. The disconnect device must be marked as such, clearly visible, directly accessible, and located within 1.8 m (6 ft) of the Model GM868. The power cord is the main disconnect device.*

Flowcell Location

The pipeline flowcell consists of the flowmeter transducers and any pressure and/or temperature transducers employed as part of the flowmeter system. Ideally, choose a section of pipe with unlimited access as the flowcell; for example, a long stretch of pipe that is above ground. However, if the flowcell is mounted on an underground pipe, dig a pit around the pipe to facilitate installation of the transducer mechanisms.

Transducer Location

For a given fluid and pipe, the Model GM868's accuracy depends primarily on the location and alignment of the transducers. In addition to accessibility, when planning for transducer location, adhere to the following guidelines:

1. Locate the transducers so that there are at least 20 pipe diameters of straight, undisturbed flow upstream and 10 pipe diameters of straight, undisturbed flow downstream from the measurement point. To ensure undisturbed flow, avoid: sources of turbulence in the fluid such as valves, flanges, expansions and elbows; swirl; and dips or low spots in which condensed liquid may collect.
2. Because condensate or sediment at the bottom of the pipe may cause attenuation of the ultrasonic signal, locate the transducers on the side of a horizontal pipe, where possible. If limited pipe access necessitates top-mounted transducers and the sound beam path includes a reflection, shift the transducers to at least 10° off top center. This will minimize the influence of any sediment on the reflected ultrasonic signals.

Cable Lengths	Locate the flowcell/transducers as close as possible to the electronics console. The factory supplies transducer cables up to 500 ft (153 m) in length. If longer cables are required, consult the factory for assistance.
Temperature and Pressure Transmitters	When installing temperature and/or pressure transmitters in the flowcell, locate them downstream of the flowmeter transducers. These transmitters should be positioned no closer to the flowmeter transducers than 2 pipe diameters and no further away from the flowmeter transducers than 20 pipe diameters.
Transducer Cables	<p>When installing the transducer cables, always observe established standard practices for the installation of electrical cables. Specifically, do not route transducer cables alongside high amperage AC power lines or any other cables that could cause electrical interference. Also, protect the transducer cables and connections from the weather and corrosive atmospheres.</p> <p>Note: <i>When using non-GE cables to connect the flowmeter transducers to the Model GM868 electronics console, the cables must have electrical characteristics identical to the GE cables. Type RG 62 a/u coaxial cable should be used, and each cable must be the same length (within ± 4 in.).</i></p>

Installing a Flowcell

A flowcell is the section of pipe where the transducers are mounted. It can be created either by mounting the transducers on the existing pipeline or by mounting them on a spoolpiece. A spoolpiece is a separately manufactured pipe section, matched to the existing pipe, which contains ports for mounting the transducers. This approach allows the transducers to be aligned and calibrated before inserting the spoolpiece into the pipeline.

Figure 1-1 on page 1-4 shows a block diagram of a typical Model GM868 system, including optional pressure and temperature transmitters. For detailed instructions on installing the transducers and/or spoolpiece, refer to the supplied drawings and the *GE Gas Transducer Installation Guide for Ultrasonic Flowmeters*.

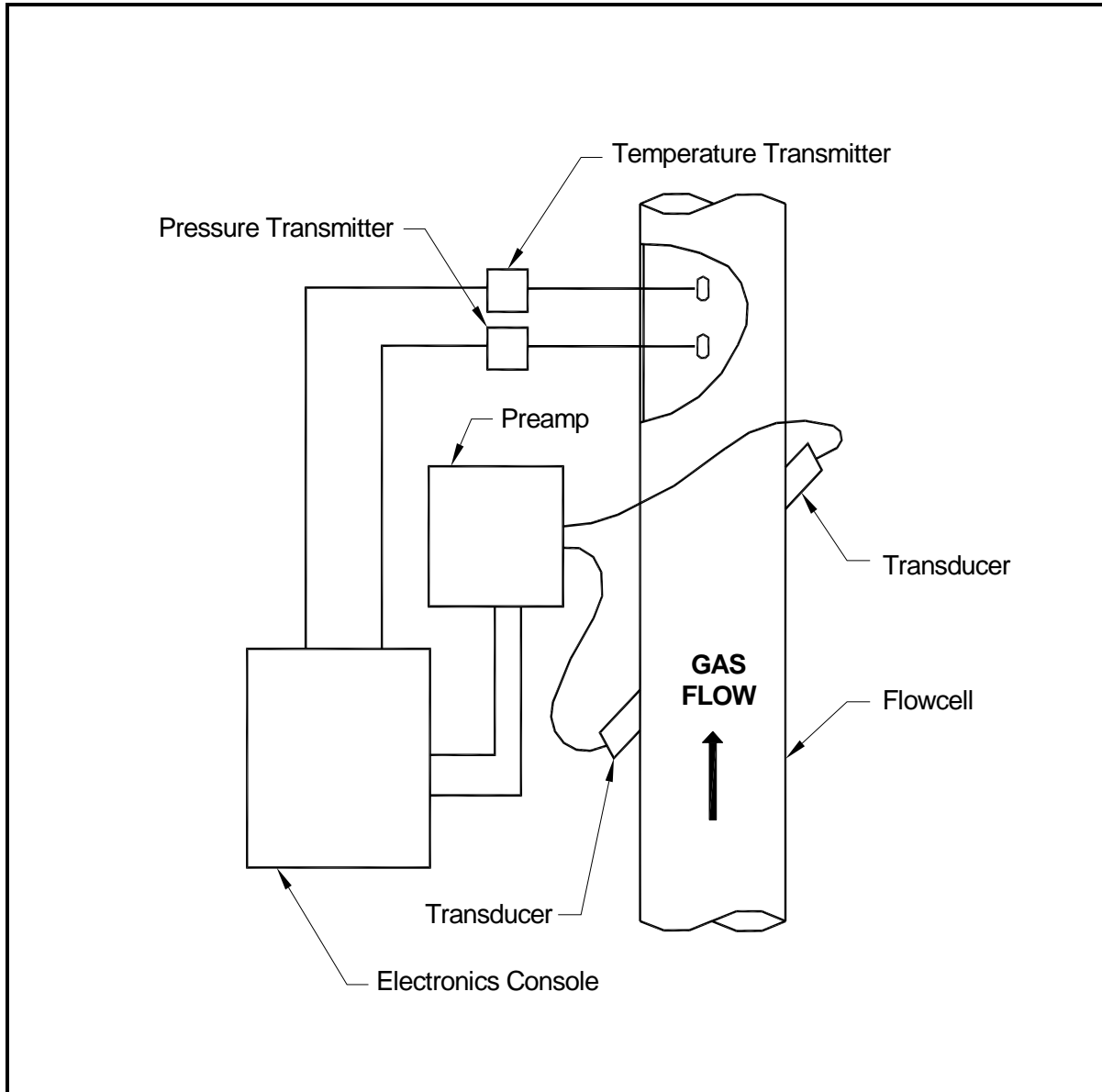

Figure 1-1: A Typical Model GM868 System

Installing Temperature and Pressure Transmitters

Optional temperature and pressure transmitters may be installed as part of the flowcell, near the ultrasonic transducer ports. Be sure to observe the siting requirements given earlier in this chapter. These transmitters must use a 0/4-20 mA signal to transmit the temperature and pressure values to the Model GM868 electronics console. In turn, the electronics console will provide a 24 VDC signal to power the transmitters. Any desired transmitters or sensors may be used, but they must have an accuracy equal to 0.5% of the reading or better.

Note: *Resistive Thermal Devices (RTDs) are a good choice for measuring the temperature.*

Typically, a 1/2" NPT female threaded port is used to mount the transmitters on the flowcell. If the pipeline is insulated, the coupling may need to be extended to provide convenient access. Of course, other types of mounting ports, including flanged ports, may be used for the transmitters.

IMPORTANT: *Under changing temperature and pressure conditions, the Model GM868 can calculate standard volumetric flow accurately only if temperature and pressure transmitters have been installed.*

Figure 1-2 below shows a typical mounting arrangement for the pressure and temperature transmitters. The temperature sensor should protrude 1/4 to 1/2 way into the pipe.

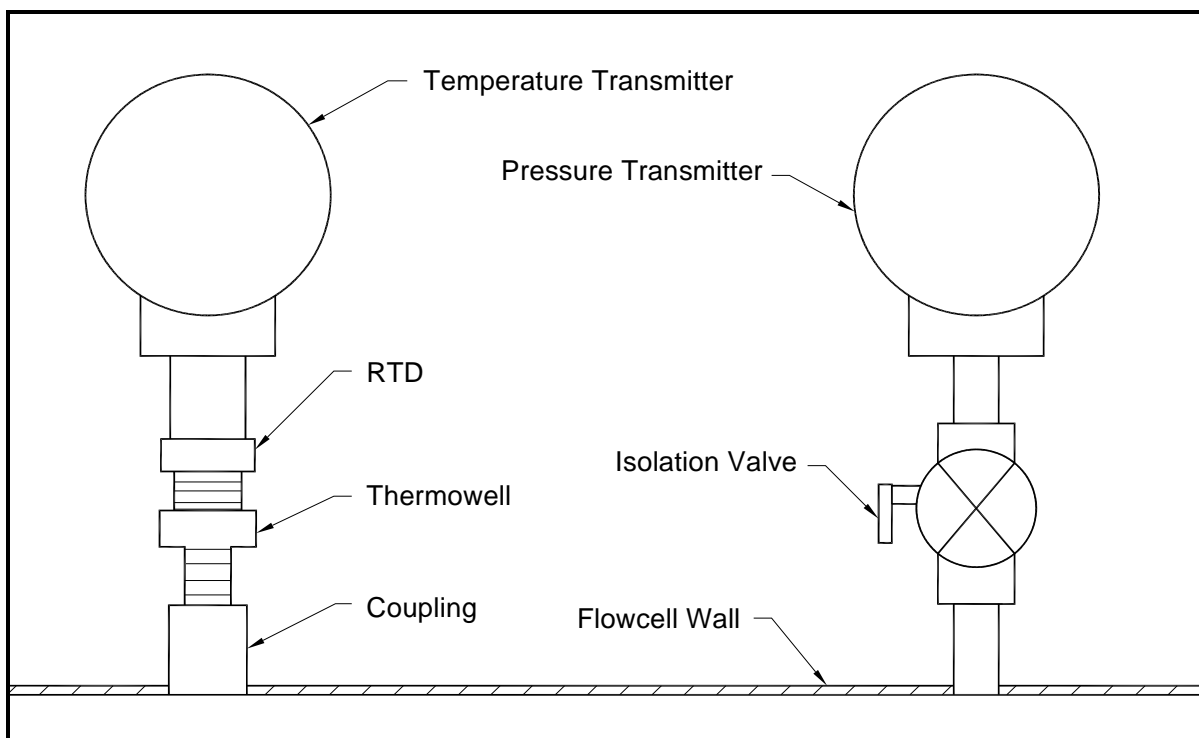

Figure 1-2: Typical Temperature/Pressure Transmitter Mounting

Mounting the GM868 Electronic Console

The standard Model GM868 electronics package is housed in a Type-4X weather-resistant enclosure. Refer to Figure 1-9 on page 1-19 for the mounting dimensions of this enclosure. For meters housed in one of the optional enclosures, a dimensional drawing will be shipped with the unit.

IMPORTANT: *For meters supplied in one of the optional enclosure styles, refer to Appendix C, Optional Enclosures, for specific mounting dimensions and instructions.*

!WARNING!

Proper grounding of the GM868 chassis is required to prevent the possibility of electric shock. See Figure 1-10 on page 1-20 to locate the internal ground connection.

Making the Electrical Connections

ATTENTION EUROPEAN CUSTOMERS!

To meet CE Mark requirements, all cables must be installed as described in Appendix A, CE Mark Compliance.

This section contains instructions for making all the necessary electrical connections to the Model GM868 flowmeter. Refer to Figure 1-10 on page 1-20 for a complete wiring diagram of the unit.

IMPORTANT: *For meters supplied in one of the optional enclosure styles, refer to Appendix C, Optional Enclosures, for the appropriate wiring diagram and specific wiring instructions.*

Except for the power connector, all electrical connectors are stored in their terminal blocks during shipment and may be removed from the enclosure for more convenient wiring. Feed the cables through the conduit holes on the bottom of the enclosure, attach the wires to the appropriate connectors and plug the connectors back into their terminal blocks.

Note: *For compliance with the European Union's Low Voltage Directive (73/23/EEC), a transparent plastic shroud protects the electrical connections. The shroud must remain in place, except while wiring the unit. Reinstall the shroud after the wiring has been completed.*

Once the Model GM868 is completely wired, proceed to Chapter 2, *Initial Setup*, to configure the unit for operation.

ATTENTION EUROPEAN CUSTOMERS!

To meet CE Mark requirements, all cables must be installed as described in Appendix A, CE Mark Compliance.

The Model GM868 may be ordered for operation with power inputs of 100-120 VAC, 220-240 VAC, or 12-28 VDC. The label on the shroud inside the electronics enclosure, just above the TB1 line power terminal block, lists the required line voltage and the fuse rating for the unit (the fuse rating is also listed in Chapter 4, *Specifications*). Be sure to connect the meter only to the specified line voltage.

Note: *For compliance with the European Union's Low Voltage Directive (73/23/EEC), this unit requires an external power disconnect device such as a switch or circuit breaker. The disconnect device must be marked as such, clearly visible, directly accessible, and located within 1.8 m (6 ft) of the Model GM868. The power cord is the main disconnect device.*

Refer to Figure 1-3 on page 1-8 or Figure 1-10 on page 1-20 to locate terminal block TB1 and connect the line power as follows:

!WARNING!

Improper connection of the line power leads or connecting the meter to the incorrect line voltage will damage the unit. It will also result in hazardous voltages at the flowcell and associated piping and within the electronics console.

Wiring the Line Power
(cont.)

1. Remove the plastic shroud that covers the terminal blocks. Be sure to reinstall the shroud after all of the wiring has been completed.
2. Strip ¼” of insulation from the end of the power and neutral or line leads (or the positive and negative DC power leads), and ½” from the end of the ground lead.
3. Connect the ground lead to the internal ground connection located on the side panel of the enclosure (see Figure 1-3 below).

IMPORTANT: *The incoming ground lead must be connected to the internal ground connection.*

4. Connect the neutral or line lead (or the negative – DC power lead) to TB1-2, and the line power lead (or the positive + DC power lead) to TB1-3, as shown in Figure 1-3 below.

IMPORTANT: *Do not remove the existing PC board ground wire or the cover ground wire.*

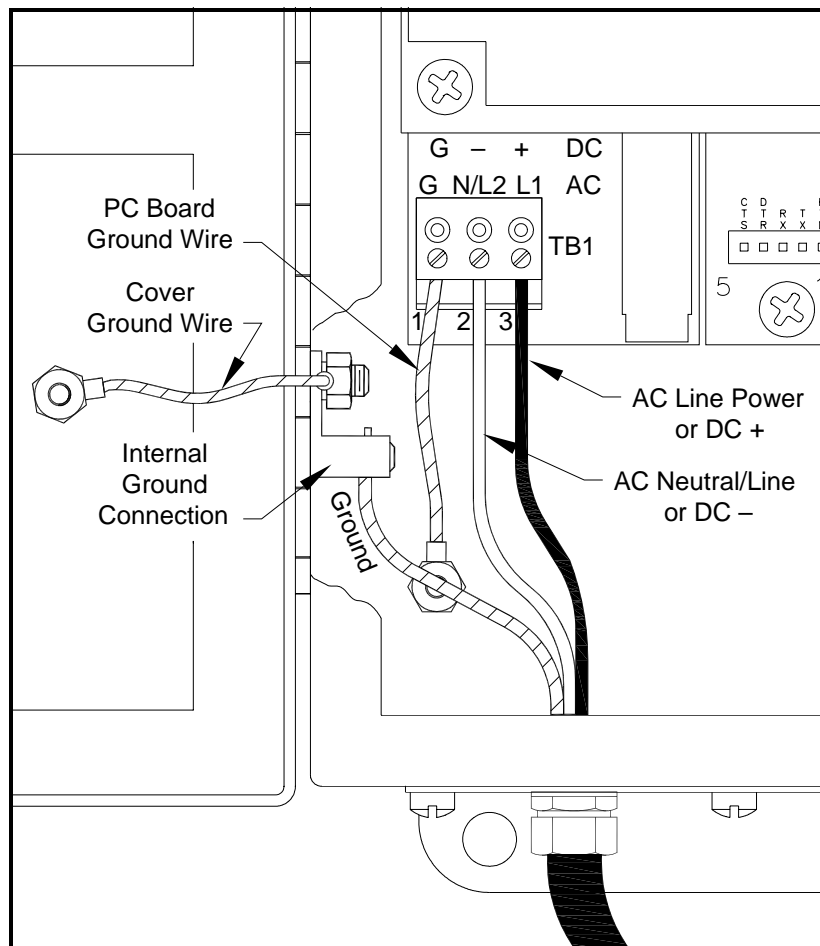

Figure 1-3: Wiring the Line Power

ATTENTION EUROPEAN CUSTOMERS!
**To meet CE Mark requirements, all cables must be installed
as described in Appendix A, CE Mark Compliance.**

Wiring a typical Model GM868 ultrasonic gas flowmeter system requires interconnection of the following components:

- a pair of transducers (per channel) mounted in the flowcell
- a preamplifier for each channel
- a lightning protector (optional)
- the electronics console

Refer to the typical transducer/flowcell wiring system in Figure 1-11 on page 1-21, and complete the following steps:

!WARNING!

Before connecting the transducers, take them to a safe area and discharge any static buildup by shorting the center conductor of the transducer cables to the metal shield on the cable connector.

1. Using the pair of coaxial cables with BNC to BNC connectors supplied by the factory (or equivalent cables), connect both transducers to the preamplifier.

Caution!

As part of maintaining the FM/CSA environmental rating (TYPE 4) on the remote preamplifier, thread sealant is required on all conduit entries.

2. If an optional lightning protector is being installed, connect it to the preamplifier.
3. Using the pair of coaxial cables with BNC to flying lead connectors supplied by the factory (or equivalent cables), connect the preamplifier to terminal block CH1 in the electronics console. Refer to Figure 1-10 on page 1-20 for the location of the terminal block and the terminal block pin assignments.
4. For a 2-channel Model GM868 flowmeter, repeat steps 1-3 to wire the Channel 2 transducer system to terminal block CH2.

Note: *It is not required that Channel 2 of a 2-channel Model GM868 be used. This channel may be left inactive for future use.*

After the wiring has been completed, the transducer channel(s) must be activated before measurements can begin. See Chapter 2, *Initial Setup*, for instructions.

Wiring the 0/4-20 mA Analog Outputs

The standard configuration of the Model GM868 flowmeter includes two isolated 0/4-20 mA analog outputs (designated as A and B). Connections to these outputs may be made with standard twisted-pair wiring. The current loop impedance for these circuits must not exceed 550 ohms. Refer to Figure 1-10 on page 1-20 for the location of terminal block I/O and wire the terminal block as shown.

Wiring the Serial Port

The Model GM868 is equipped with a built-in serial communications port. The standard port is an RS232 interface, but an optional RS485 interface is available upon request. Proceed to the appropriate subsection for wiring instructions. For more information on serial communications, refer to the *EIA-RS Serial Communications Manual* (916-054).

Wiring the RS232 Interface

The RS232 communications port provides a serial interface for connecting the Model GM868 flowmeter to a printer, an ANSI terminal or a personal computer.

The RS232 serial interface is wired as Data Terminal Equipment (DTE), and the signals available at the Model GM868 RS232 terminal block are shown in Table 1-1 below. Refer to Figure 1-10 on page 1-20 to locate terminal block RS232 and complete the following steps to wire the terminal:

1. Use the information in Table 1-1 below to construct a suitable cable for connecting the Model GM868 to the external device. If desired, an appropriate cable may be purchased from GE.

Table 1-1: RS232 Connection to DCE or DTE Device

RS232 Pin #	Signal Description	DCE DB25 Pin #	DTE DB25 Pin #	DTE DB9 Pin #
1	RTN (Return)	7	7	5
2	TX (Transmit)	3	2	3
3	RX (Receive)	2	3	2
4	DTR (Data Terminal Ready)	20	20	4
5	CTS (Clear to Send)	4	5	8

2. Wire the flying leads end of the cable to terminal block RS232 and connect the other end of the cable to the printer, ANSI terminal or personal computer.

After the wiring has been completed, consult the User's Manual for the external device to configure it for use with the Model GM868.

Wiring the RS485 Interface Use the optional RS485 serial port to network multiple GM868 flowmeters to a single computer terminal. Upon request, the standard RS232 port on the GM868 may be configured as a two-wire, half-duplex RS485 interface, through a device such as the INMAC Model 800052 RS232-RS422/RS485 converter.

To wire the RS485 serial port, refer to Figure 1-10 on page 1-20 and complete the following steps:

1. Disconnect the main power to the unit and remove the cover.
2. Install the required cable clamp in the chosen conduit hole on the side of the electronics enclosure.
3. Feed one end of the cable through the conduit hole, wire it to terminal block J1 and secure the cable clamp. Connect the other end of the cable to the converter, as shown in Figure 1-4 below.

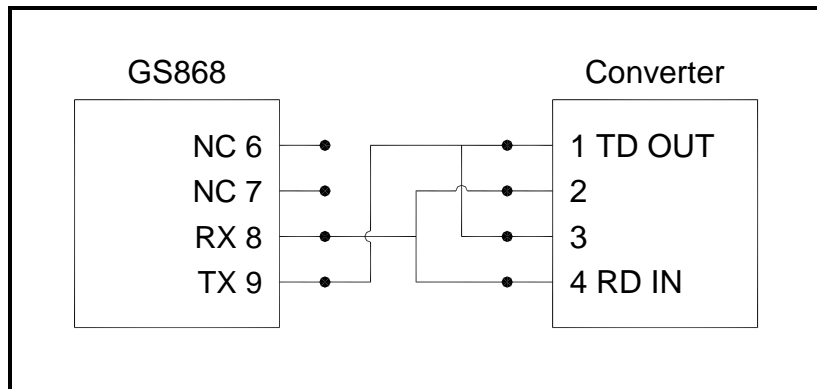

Figure 1-4: Typical RS485 Connections

!ATTENTION EUROPEAN CUSTOMERS!
To meet CE Mark requirements, all cables must be installed as described in Appendix A, *CE Mark Compliance*.

4. If wiring of the unit has been completed, reinstall the rear cover on the enclosure and tighten the set screw.

Wiring the Ethernet Interface

A modified GM868 can use the Ethernet interface to communicate to an internal network. An optional Ethernet card with a unique MAC (IP) address (installed only in slots 5 or 6) includes an RJ45 connector. To connect the Ethernet-enabled GM868 to the network, insert the jack of an RJ45 cable into the RJ45 connector, route the cable through the bottom of the GM868, and wire the other end of the cable to the Ethernet network according to the manufacturer’s instructions. An external connection is required between the Ethernet option card and the GM868 RS232 connector, as shown in Table 1-2 below.

Note: *The MAC address for a specific GM868 is included with customer documentation. For more information on setting up the MAC address, refer to Chapter 6 of the Programming Manual.*

Table 1-2: RS232 to Ethernet Interconnections

GM868 Type	Terminal Block	Terminal Block
Wall Mount	RS232 on Main Board	TB1 on Ethernet Card
	TX	Pin 1
	RX	Pin 2
	RTN	Pin 3
Rack Mount	RS232 on Main Board	TB2 on Ethernet Card
	TX	Pin 1
	RX	Pin 2
	RTN	Pin 3

Wiring the MODBUS/TCP Interface

Customers can also use a modified GM868 that provides a MODBUS/TCP interface to communicate to an internal network. An optional MODBUS/TCP card with a unique MAC (IP) address (installed only in slots 5 or 6) includes an RJ45 connector. To connect the MODBUS/TCP-enabled GM868 to the network, insert the jack of an RJ45 cable into the RJ45 connector, route the cable through the bottom of the GM868, and wire the other end of the cable to the Ethernet network according to the manufacturer’s instructions.

Note: *The MAC address for a specific GM868 is included with customer documentation. For more information on setting up the MAC address, refer to Chapter 6 of the Programming Manual.*

Wiring the Foundation Fieldbus Network

Fieldbus network connections are made at J8/J9, pins 1 and 2 (see Figure 1-5 below). Optionally, a shield can be connected to J8/J9 pin 3, depending on the network wiring. Connector J8 or J9 will be installed depending on the option ordered by the customer.

No connections are made to J8/J9, pins 7 and 9, under normal operation. If it is desired to reset the network board to factory defaults:

1. Connect a jumper between J8/J9 pin 7 and pin 9.
2. Power cycle the instrument.
3. Ten seconds after the power has been restored to the unit, remove the jumper to return the network board to normal operation.

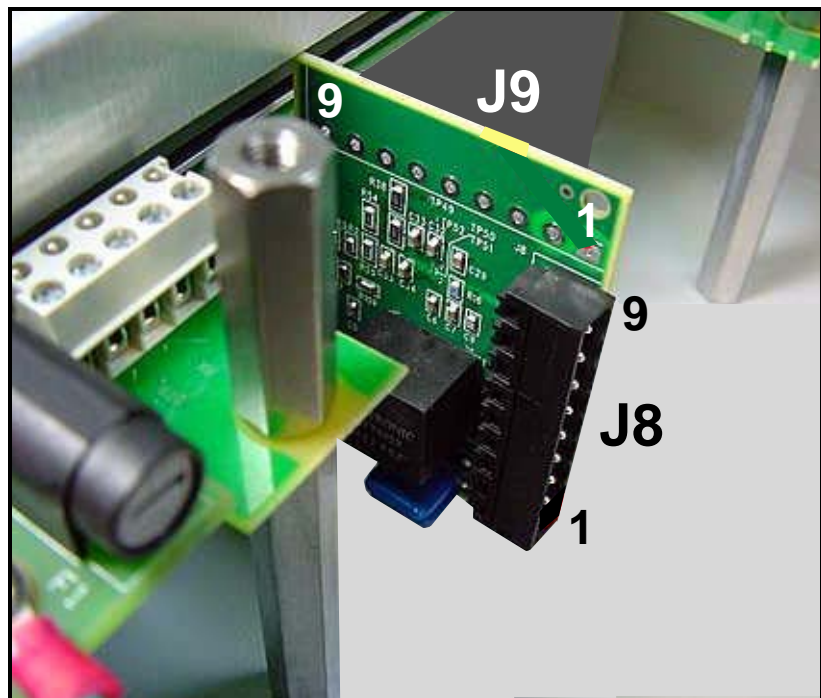

Figure 1-5: Network Connections - Standard Option Interior

Wiring an Alarms Option Card

The Model GM868 flowmeter can accommodate up to 4 alarm option cards. Each alarms option card includes three *Form C relays* (designated as A, B and C).

The alarm relays on the option card are available in two types:

- general purpose
- hermetically sealed for Class I, Division 2 hazardous areas.

The maximum electrical ratings for the relays are listed in Chapter 4, *Specifications*. Each of the three alarm relays can be wired either as *Normally Open (NO)* or *Normally Closed (NC)*.

In setting up an alarm relay, it may be wired for either *conventional* or *fail-safe* operation. In fail-safe mode, the alarm relay is constantly energized, except when it is triggered by a power failure or other interruption. See Figure 1-6 below for the operation of a NO alarm relay in both conventional and fail-safe mode.

Connect the two wires required for each alarm relay in accordance with the pin number assignments shown in Figure 1-10 on page 1-20.

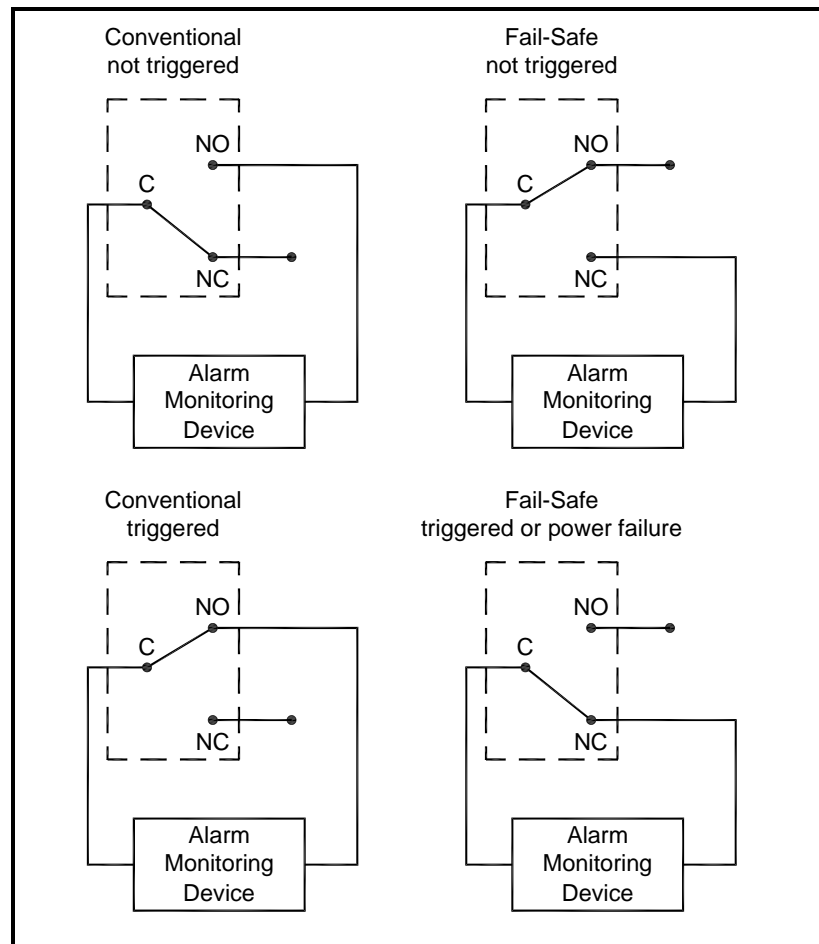

Figure 1-6: Conventional and Fail-Safe Operation

Wiring a 0/4-20 mA
Analog Inputs Option Card

To calculate the standard volumetric flow rate of natural gas, the Model GM868 requires accurate *temperature* and *pressure data* from the measurement site. Transmitters installed in the flowcell can provide this information via an optional 0/4-20 mA analog inputs card. This option card includes two isolated 0/4-20 mA analog inputs (designated as A and B), each of which includes a 24 VDC power supply for loop-powered transmitters. Either input may be used to process the temperature signal, while the other input is used to process the pressure signal.

Note: *To enter programming data during operation of the meter, it will be necessary to know which input is assigned to which process parameter. This information should have been entered in Appendix B, Data Records.*

The analog inputs, which have an impedance of 118 ohms, should be connected with standard twisted-pair wiring. Power to the transmitters may be supplied either by the integral 24 VDC power supply on the analog input card or by an external power supply. Figure 1-6 below shows typical wiring diagrams, with and without an external power supply, for one of the analog inputs.

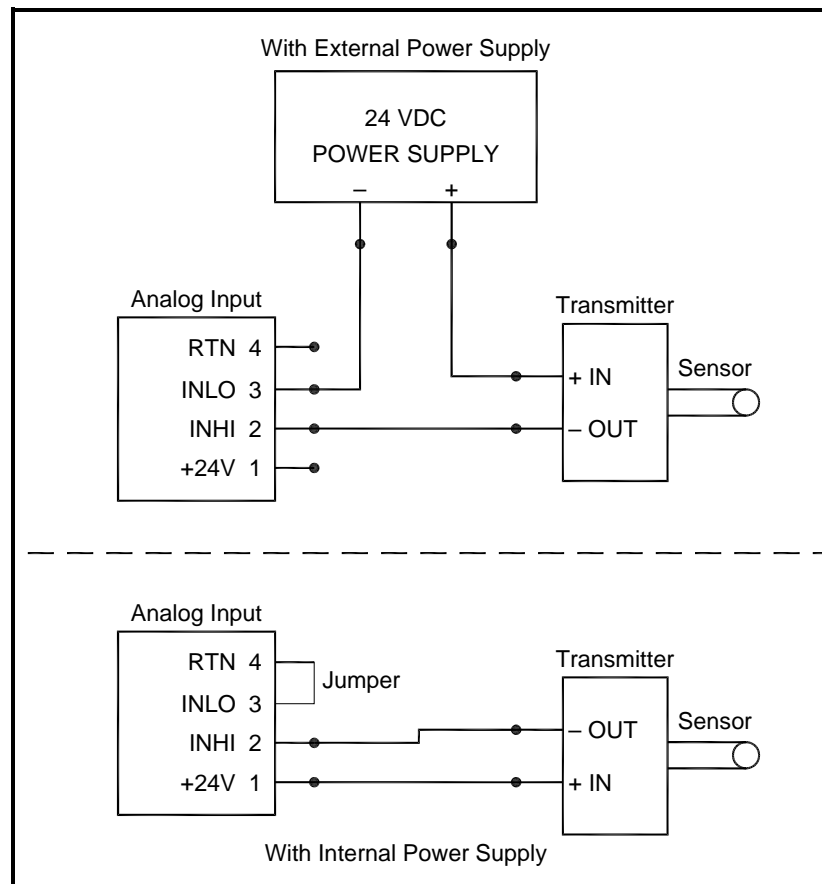

Figure 1-7: Analog Input Wiring Diagram

Wiring a 0/4-20 mA
Analog Inputs Option Card
(cont.)

Wire the analog input terminal block in accordance with the pin number assignments shown in Figure 1-10 on page 1-20.

If the flowmeter system includes additional transmitters, the Model GM868 can accommodate up to three more analog inputs option cards. These option cards are identical to the temperature/pressure card described above and they should be wired in the same manner (see Figure 1-7 on the previous page).

The analog inputs on the option card(s) can be calibrated with the Model GM868's built-in analog outputs. However, be certain that the analog outputs have been calibrated first. See Chapter 1, *Calibration*, in the *Service Manual* for the appropriate procedures.

Wiring a Totalizer/
Frequency Outputs Option
Card

The Model GM868 can accommodate up to four totalizer/frequency outputs option cards. Each totalizer/frequency outputs option card provides four outputs (designated as A, B, C, and D) that can be used as either totalizer or frequency outputs.

Each totalizer/frequency output requires two wires. Wire this terminal block in accordance with the pin number assignments shown in Figure 1-10 on page 1-20. Figure 1-8 below shows sample wiring diagrams of a totalizer output circuit and a frequency output circuit.

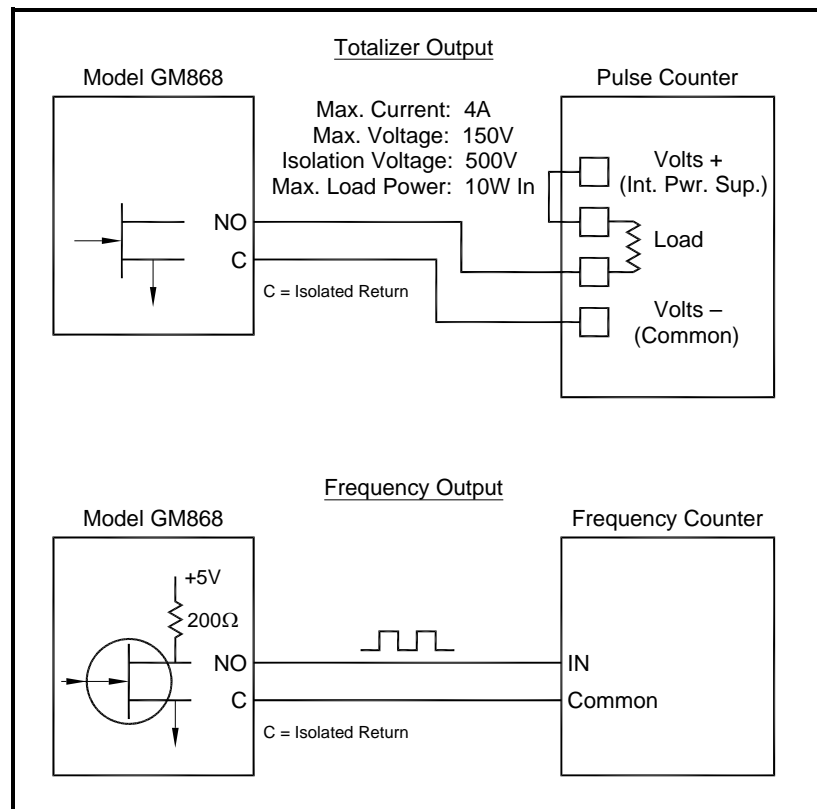

Figure 1-8: Totalizer/Frequency Outputs Wiring

Wiring an RTD Inputs Option Card

The Model GM868 can accommodate up to four RTD (Resistance Temperature Device) inputs option cards. Each RTD inputs option card provides two direct RTD inputs (designated as A and B).

Each RTD input requires three wires, which should be fed through one of the conduit holes on the bottom of the electronic console. Wire this terminal block in accordance with the pin number assignments shown in Figure 1-10 on page 1-20.

Wiring a 0/4-20 mA Analog Outputs Option Card

The Model GM868 flowmeter can accommodate up to 4 analog outputs option cards. Each analog outputs option card includes four isolated 0/4-20 mA outputs (designated as A, B, C and D).

Connections to these outputs may be made with standard twisted-pair wiring. The total current loop impedance for these circuits must not exceed 1000 ohms. Wire this terminal block in accordance with the pin number assignments shown in Figure 1-10 on page 1-20.

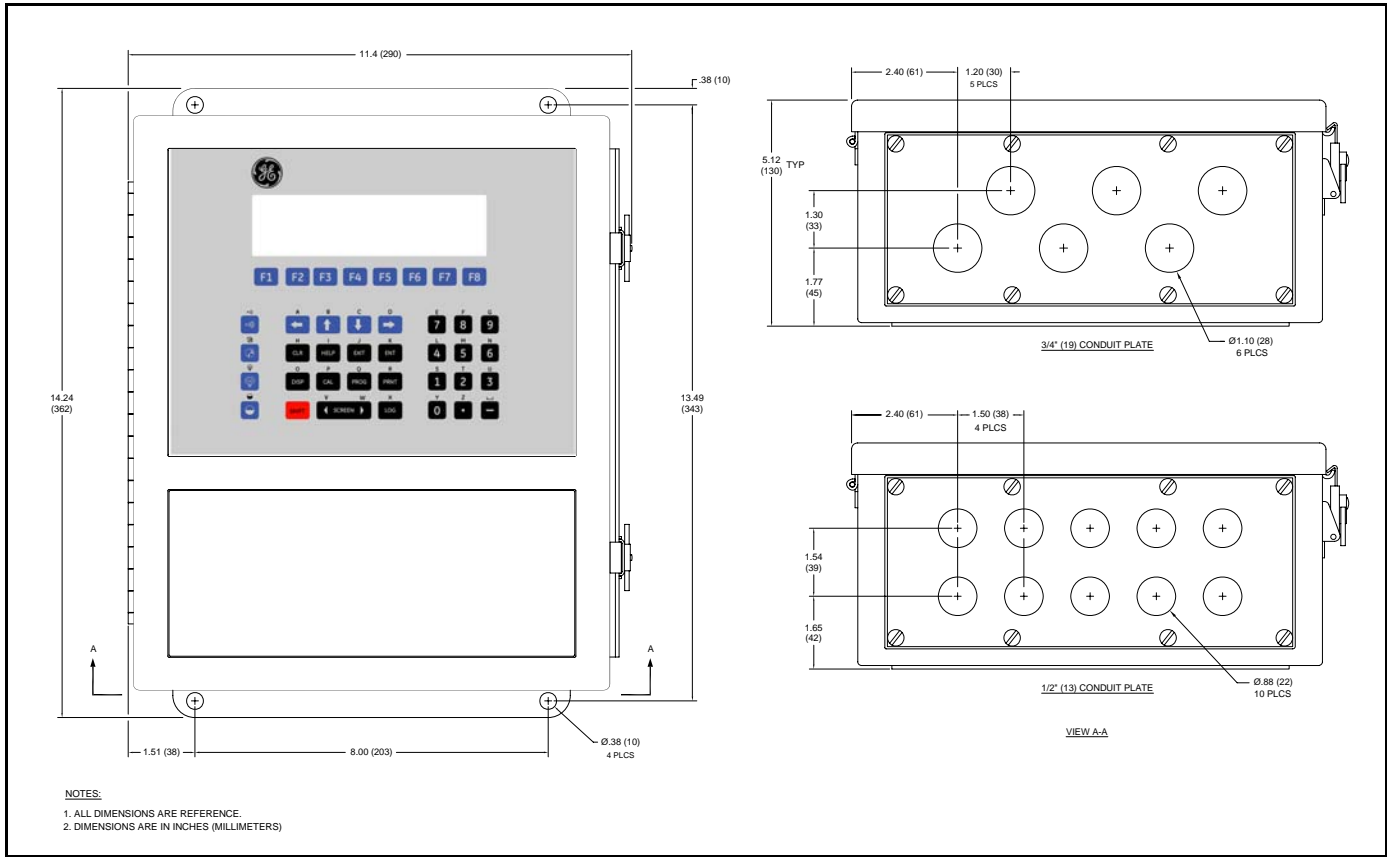

Figure 1-5: Model GM868 Type 4X Enclosure (ref. dwg # 712-1056)

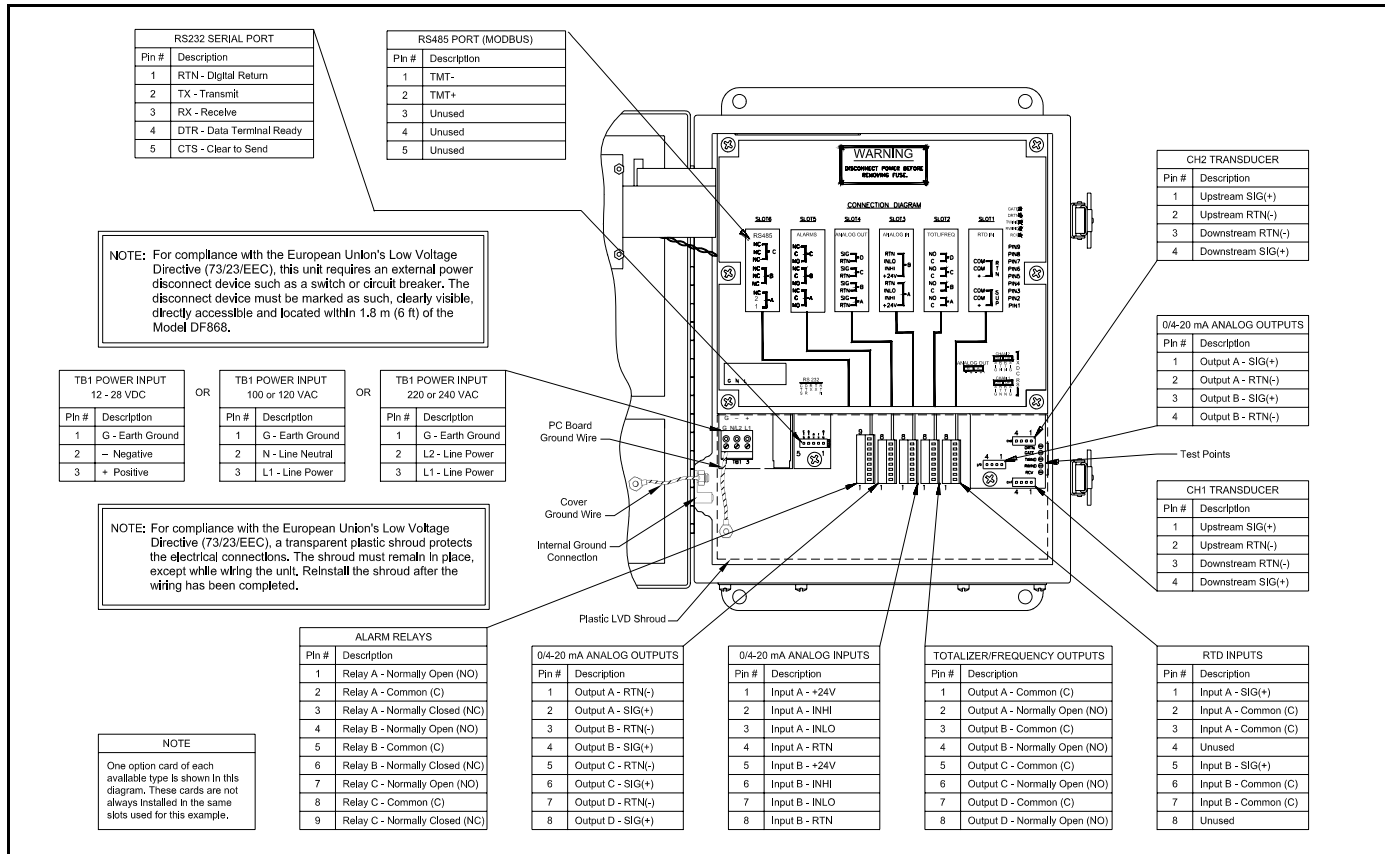

Figure 1-10: Model GM868 Electronics Console Wiring (ref. dwg #702-213, sht 1)

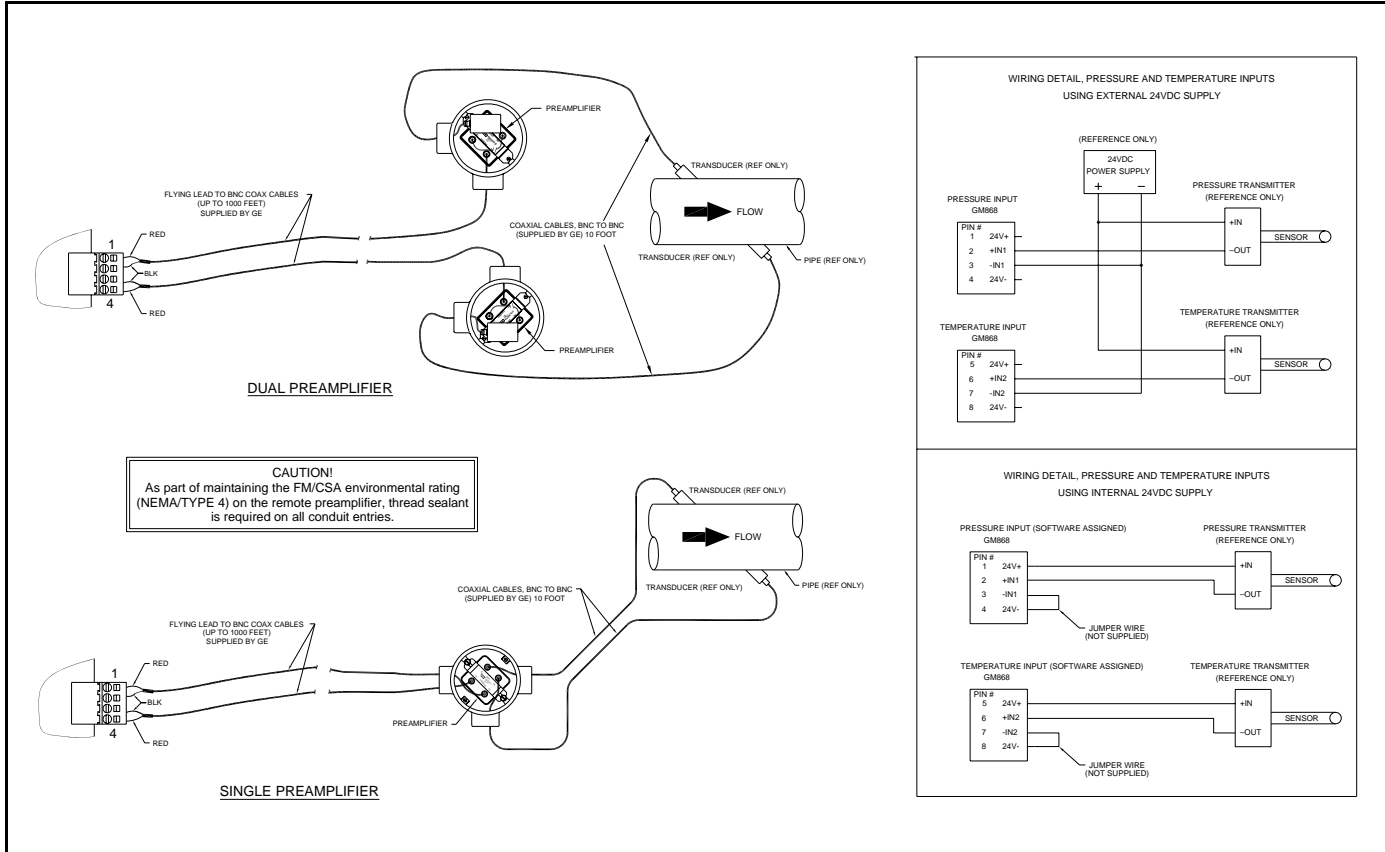

Figure 1-1-1: Model GM868 Transducer Wiring (ref. dwg #702-213, sht 2)

Chapter 2

Initial Setup

- Introduction..... 2-1
- Navigating Through the User Program..... 2-1
- Accessing the User Program..... 2-2
- Activating a Channel..... 2-3
- Entering System Data for a Channel..... 2-4
- Entering Pipe Data..... 2-7

Introduction

This chapter provides instructions for entering the minimum amount of programming data required to place the Model GM868 flowmeter into operation. Before the Model GM868 can begin taking measurements and displaying valid data, the current system and pipe parameters must be entered. In addition, a 2-Channel meter requires that each channel be activated prior to use. Additional programming options provide access to the more advanced features of the Model GM868, but this information is not required to begin taking measurements.

Note: *See the Programming Manual for information on those User Program options not covered in this chapter. If you are using PanaView™ software, see Appendix C in the Programming Manual.*

Navigating Through the User Program

In order to begin using the Model GM868, the following submenus within the *User Program* will be accessed:

- ACTIV - enables selection of the desired measurement method (for a 2-Channel meter, it is also used to activate a channel)
- SYSTM - prompts the user to enter the required system data
- PIPE - prompts the user to enter the required pipe parameters

As a guide in following the programming instructions in this chapter, the relevant portions of the Model GM868 menu map have been reproduced in Figure 2-1 on page 2-11.

Note: *There are minor differences at the start of the ACTIV and SYSTM submenus for the 1-Channel and 2-Channel models, but the PIPE submenus are identical.*

The following discussion assumes that the left screen pane is active. If the right screen pane is active, only the function key designations change. That is, replace [F1]-[F4] with [F5]-[F8]. Be sure to record all programming data in Appendix B, *Data Records*.

Use the keypad, as described in the *Programming Manual*, to navigate through the *User Program*. The menu map may be followed in sequence, or the [↑] and [↓] keys may be used to scroll through the prompt screens. The [←] key may be used to delete the last alphanumeric character that was entered from the keypad.

Accessing the User Program

To access the *User Program*, press the [PROG] key on the keypad.

Note: *If the security feature is active, enter the password and press [ENT] to enter the User Program. See the SECUR submenu section in Chapter 1 of the Programming Manual for more information on the security feature.*

For a 1-Channel Model GM868, the measurement mode screen is replaced by the following initial programming mode screen:

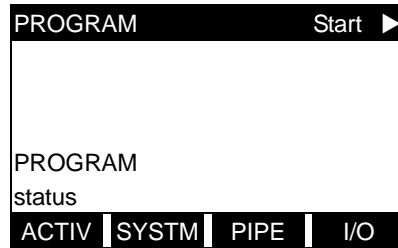

At the *User Program* screen shown, press [F1] and proceed to “*The ACTIV Submenu*” section for instructions.

For a 2-Channel Model GM868, the following two-step sequence is required to reach the initial programming screen:

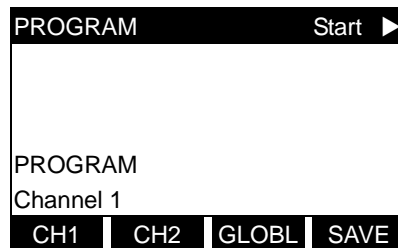

Press [F1] or [F2] to select the submenu for Channel 1 or Channel 2, respectively, from the option bar.

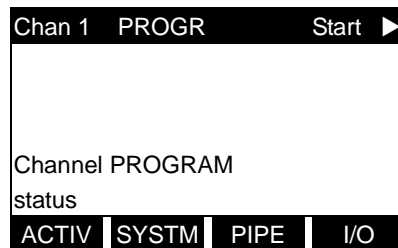

At the *User Program* screen shown, press [F1] and proceed to “*The ACTIV Submenu*” section for instructions.

Only the submenus *ACTIV*, *SYSTM* and *PIPE* are discussed in this manual. Refer to the *Programming Manual* for information on the other submenus.

Note: *In this manual, only the programming of Channel 1 will be described. To program Channel 2, simply repeat the same procedures presented for Channel 1.*

Activating a Channel

The ACTIV submenu permits selection of the desired measurement method. In addition, it is used to activate/deactivate one or both of the channels in a 2-Channel Model GM868.

1-Channel Meter

1. Enter the ACTIV submenu by pressing [F1] at the User PROGRAM prompt.
2. Press [F1] to activate the channel in BURST mode.

2-Channel Meter

1. Enter the ACTIV submenu by pressing [F1] at the Channel PROGRAM prompt.
2. Press [F1] (OFF) to deactivate the channel and return to the Channel PROGRAM prompt, or press [F2] to activate the channel in BURST mode.

1 and 2-Channel Meters

3. Press [F1] to select *Skán* mode or [F2] to select *Skán/Measure* mode. The meter will exit the ACTIV submenu and return to the channel menu screen.

As indicated in the above prompt, the Model GM868 flowmeter can take measurements in two different ways

Skán is a low resolution technique for locating the acoustic signal and for high velocity measurements. It is more robust in a noisy environment than the *Measure* technique.

Measure is a more precise technique best used for low velocity measurements.

If *Skán* is selected at the next prompt, the instrument uses this technique exclusively. However, if *S/M* is selected, the meter uses *Skán* to find the acoustic signal and then tries to use the *Measure* technique for a more precise measurement.

Proceed directly to the next section to program the SYSTM submenu.

Entering System Data for a Channel

Begin the programming of the SYSTM submenu in either the *1-Channel* or *2-Channel* section below.

1-Channel Meter

For the 1-Channel Model GM868, the information entered in the SYSTM submenu pertains to the global operation of the flowmeter.

1. At the *User Program* screen, press the [F2] function key to program the SYSTM submenu.
2. Enter a *Site Label* of up to 9 characters and press [ENT]. (While taking measurements, the site label will appear on the locator bar.)
3. Enter a *Site Message* of up to 21 characters. Press [ENT].
4. To select the *System Units*, press [F1] to display parameters and measurements in English units, or press [F2] to display parameters and measurements in Metric units.
5. Use the [F1]-[F4] keys to select the type of *Pressure Units* desired.

The abbreviations and definitions of all the available pressure units are shown in Table 2-1 below. The choices shown on the option bar are determined by the selections made at the previous SYSTEM UNITS prompt.

Table 2-1: Available Pressure Units

English	Metric
PSIa = Pounds per square inch absolute	BARa = bar absolute
PSIg = Pounds per square inch gage	BARg = bar gage
	kPaa = kiloPascals absolute
	kPag = kiloPascals gage

6. If you have entered gage pressure, or the local atmospheric pressure (PSIg, BARg or kPag), use the numeric keys to enter the gage pressure value. Press [ENT].
7. At the *Stopwatch Totalizer* prompt, press [F1] to totalize all liquid flow continuously, or [F2] to measure totals manually with the Stopwatch Timer. (With MNUAL ([F2]), the console key on the keypad is used to start and stop the totalizer. See the *Programming Manual* for details.)

The remainder of the SYSTM submenu is identical for the 1-Channel and 2-Channel versions of the Model GM868. Proceed to the *1- and 2-Channel Meters* section to complete the programming of this submenu.

2-Channel Meter

For the 2-Channel Model GM868, the information entered in the SYSTM submenu pertains only to the currently selected channel.

1. At the *User Program* screen shown, press the [F2] function key to program the SYSTM submenu.
2. Enter a *Channel Label* of up to 9 characters. Press [ENT].
3. Enter a *Channel Message* of up to 21 characters. Press [ENT].

Note: For the 2-Channel Model GM868, the System Units, Pressure Units and Stopwatch Totalizer prompts, which are not required to make the unit operational, are located in the GLOBL submenu. See the Programming Manual for details.

The remainder of the SYSTM submenu is identical for the 1-Channel and 2-Channel versions of the Model GM868. Proceed to the *1- and 2-Channel Meters* section below to complete the programming of this submenu.

1 and 2-Channel Meters

1. At the *Equation* prompt, press [F1] to display the measurement data in *standard* volumetric units, or press [F2] to display the measurement data in *actual* volumetric units. The Model GM868 will use the appropriate gas equation to calculate the flow rate, corresponding to the measured data, in the volumetric units indicated.
2. Use the [F1]-[F4] and [→] keys to select the desired *Volumetric Units* for the flow rate display.

The abbreviations and definitions of all the available volumetric and totalizer units are shown in Table 2-2 below. The choices shown on the option bar are determined by the selection made at the previous SYSTEM UNITS screen.

Table 2-2: Available Volumetric/Totalizer Units

English	Metric
Actual Units	
ACF = Actual Cubic Feet	ACM = Actual Cubic Meters
KACF = Thousands of ACF	KACM = Thousands of ACM
MMACF = Millions of ACF	MMACM = Millions of ACM
Standard Units	
SCF = Standard Cubic Feet	SCM = Standard Cubic Meters
KSCF = Thousands of SCF	KSCM = Thousands of SCM
MMSCF = Millions of SCF	MMSCM = Millions of SCM

1- and 2-Channel Meters
(cont.)

3. Use the [F1]-[F4] keys to select the *Volumetric Time* (units for the volumetric flow rate display).
4. Use the [F1]-[F4] keys to select the *Vol Decimal Digits* (the desired number of digits to the right of the decimal point) in the volumetric flow rate display.
5. Use the [F1]-[F4] and [→] keys to select the *Totalizer Units*.

The abbreviations and definitions of all the available volumetric and totalizer units are shown in Table 2-2 on the previous page. The choices shown on the option bar in the prompt screen above are determined by the selection made at the previous SYSTEM UNITS prompt screen.

6. Use the [F1]-[F4] keys to select the *Total Decimal Digits* (the desired number of digits to the right of the decimal point) in the totalized flow display.
7. Use the [F1]-[F4] keys to select the *Mass Flow* units, listed in Table 2-3 below.

Table 2-3: Available Mass Flow Units

English Mass Flow Units	Metric Mass Flow Units
LB- Pounds	KG - Kilograms
KLB - Thousands of Pounds	
MMLB - Millions of Pounds	
TONS - Tons	Tonnes - Metric Tons

8. Use the [F1]-[F4] keys to select the *Mass Flow Time* units.
9. Use the [F1]-[F4] keys to select the *MDOT Decimal Digits* (the number of digits to the right of the decimal point) for displaying mass flow.
10. Use the [F1]-[F4] keys to select the *Mass (Totalizer)* units, listed in Table 2-3 above.
11. Use the [F1]-[F4] to specify the *Mass Decimal Digits* (the number of digits to the right of the decimal point) for displaying totalized mass flow. The meter returns to the initial *User (or Channel) Program* screen.
12. Proceed directly to the next section to program the PIPE submenu.

Entering Pipe Data

The PIPE submenu permits entry of the transducer and pipe specifications. To program this menu, complete the following steps:

1. At the *User (or Channel) Program* screen, press [F3] to program the PIPE submenu.
2. Enter the *Transducer Number* (normally engraved on the head of the transducer). Press [ENT]. If there is no engraved number, complete the steps below. Otherwise, proceed to step 3.

IMPORTANT: *Special transducers, which have no engraved number on the head, are rarely used. Examine the transducer head carefully for a number.*

Special Transducers

- a. Assign a number between 91 and 99 to the *Special Transducer* and press [ENT]. (The meter will only accept values from 1 to 199.)
- b. Use the [→] and [F1]-[F4] keys to select the *Frequency* of the special transducer. The meter can not transmit an excitation voltage at the transducer's natural frequency without this data.
- c. Enter the special transducer *Time Delay (Tw)* value supplied by the factory. Press [ENT]. (The meter will only accept values from 0 to 1000 μ sec.)

Note: *Tw is the time required for the transducer signal to travel through the transducer and its cable. This time delay must be subtracted from the transit times of the upstream and downstream transducers to ensure an accurate measurement.*

Pipe OD

3. Enter the known *Pipe OD* or circumference and use the [F1]-[F4] keys to select the appropriate units. Press [ENT]. (The meter will only accept values from 1/8 to 648 in.)

The required pipe data may be obtained by measuring either the pipe outside diameter (OD) or circumference at the transducer installation site. Alternatively, the information may be obtained from tabulated data for standard pipe sizes.

Pipe Wall

4. Enter the known thickness of the *Pipe Wall*, in the same units used for the pipe OD. Press [ENT]. (The meter will only accept values from 0 to 4 in.)

If the pipe wall thickness is not known and cannot be conveniently measured, look up the value in a table of standard pipe size data or use the Model GM868's on-line *Help Menu*.

Path Length

5. Press [F1] = inch or [F2] = feet to select the units. Then, enter the *Path Length (P)* of the ultrasonic signal. Press [ENT]. (The meter will only accept values from 1/8 to 900 in.)

Note: *The factory has calculated both the transducer signal path length (P) and the transducer signal axial length (L), based on the exact transducer configuration used for the application. These values are engraved on the flowcell and/or are included in the documentation supplied with the meter.*

Axial Length

6. Press [F1] = inch or [F2] = feet to select the units. Then, enter the *Axial Length (L)* of the ultrasonic signal and press [ENT].

Fluid Type

7. Press [F1] = air or [F2] = any other gas to select the *Fluid Type*.
 - a. If OTHER was selected, enter the speed of sound (in feet per second) in the gas to be measured. Press [ENT]. (The meter will only accept values from 125 to 9000 ft/sec.)

Reynolds Correction

8. Press [F1] to turn *Reynolds Correction* off, or [F2] to turn it on.

Note: *Reynolds Correction is a number based on the Kinematic Viscosity and flow rate of the fluid. It should be enabled for most applications.*

9. When you enable the Reynolds Correction Factor, you must also enter the *Kinematic Viscosity* of your gas, as listed in *Sound Speeds and Pipe Size Data*. Use the numeric keys to enter a value, and press [ENT].

Calibration Factor

10. Enter a value for the flow *Calibration Factor* and press [ENT]. The default value is 1.00. (The meter will only accept values from 0.5000 to 2.0000.)

Procedure Options

After completing the above steps, the meter returns to the *User (or Channel) Program* prompt. Continue as follows:

- To continue programming the meter, refer to the menu maps in the *Programming Manual* and navigate to the desired menu. Then, proceed to the appropriate section of the manual for instructions.
- To leave the *User Program* and retain the previous settings, press [EXIT] once (for a 1-channel GM868) or twice (for a 2-channel GM868) and then press [F1] = NO at the *SAVE* prompt. Any programming changes will be discarded and you will be returned to the data display.
- To leave the *User Program* and return to measurement mode, press [EXIT] once (for a 1-channel GM868) or twice (for a 2-channel GM868) and then press [F2] = YES at the *SAVE* prompt. Your programming changes will be entered into the meter's memory, and you will be returned to the data display.

Note: See the *Programming Manual* for instructions on using the *SAVE* submenu.

Proceed to Chapter 3, *Operation*, for instructions on taking measurements or refer to the *Programming Manual* for instructions on programming the Model GM868's advanced features.

Chapter 3

Operation

Introduction.....	3-1
Powering Up	3-2
Using the Display	3-3
Taking Measurements.....	3-5

Introduction

See Chapter 1, *Installation*, and Chapter 2, *Initial Setup*, to prepare the system for operation. When the meter is ready to take measurements, proceed with this chapter. The following specific topics are discussed:

- Powering Up
- Using the Display
- Taking Measurements

Note: *All inputs and outputs of the Model GM868 are calibrated at the factory, prior to shipment. If it becomes necessary to recalibrate any of the inputs and/or outputs, see Chapter 1, Calibration, of the Service Manual.*

!WARNING!

To ensure the safe operation of the Model GM868, it must be installed and operated as described in this manual. In addition, be sure to follow all applicable local safety codes and regulations for the installation of electrical equipment.

Powering Up

Because the Model GM868 does not have an ON/OFF switch, it will power up as soon as the connected power source is energized.

Note: *For compliance with the European Union’s Low Voltage Directive (73/23/EEC), this unit requires an external power disconnect device such as a switch or circuit breaker. The disconnect device must be marked as such, clearly visible, directly accessible, and located within 1.8 m (6 ft) of the Model GM868. The power cord is the main disconnect device.*

Immediately upon power up, the Model GM868 displays “GE” and the software version in the left pane of the display window. The Model GM868 performs a series of internal checks and display the results in the right pane of the display window.

Note: *If the Model GM868 fails any of the internal checks, try disconnecting the power and then re-powering the unit. If the Model GM868 continues to fail any of the internal checks, contact the factory for assistance.*

After successfully performing the internal checks, the Model GM868 begins taking measurements. The power up display is replaced by a measurement mode display similar to that shown in Figure 3-1 below.

Note: *As a minimum, the system and pipe parameters (for each installed channel of a 2-channel meter) must be entered before the Model GM868 can display valid data. Refer to Chapter 2, Initial Setup, for specific instructions.*

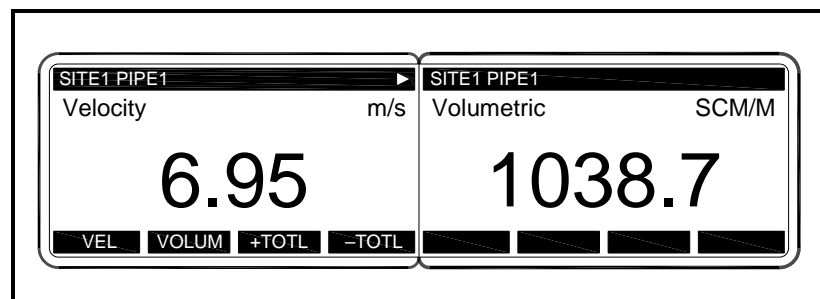

Figure 3-1: A Typical Measurement Display

Proceed to the next section for a description of the components of the Model GM868 display screen.

Using the Display

The Model GM868 display is divided into a left pane and a right pane. The two screen panes can be set independently to display any of the available measurement or diagnostic parameters. The components of a typical measurement mode screen are shown in Figure 3-2 below.

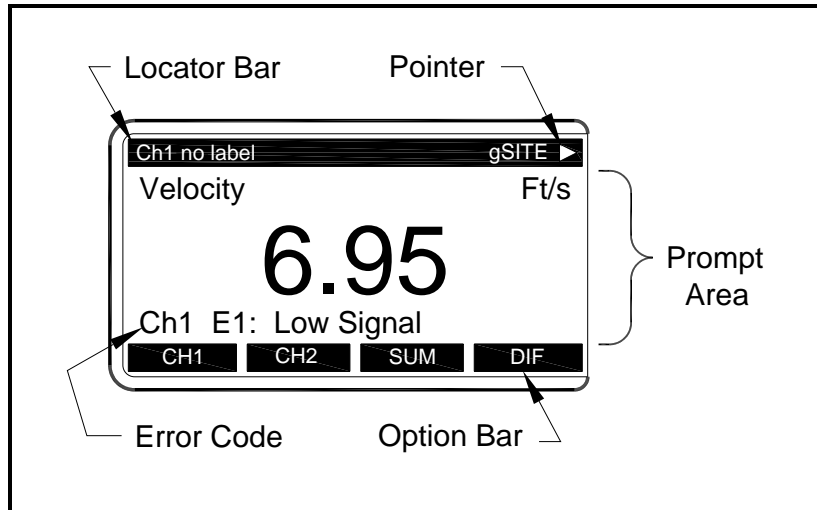

Figure 3-2: Display Screen Components

Both panes of the display screen are continuously updated, but only one pane at a time may be programmed or changed. To select a pane, press the corresponding side of the [SCREEN] key on the keypad. The currently selected screen pane will have function names in the option bar, while the other screen pane will have a blank option bar. See the *Programming Manual* for detailed instructions on using the keypad.

As shown in Figure 3-2 above, each pane of the display screen is divided into the following three general areas:

- the locator bar
- the prompt area
- the option bar.

The upper portion of the screen pane is called the *locator bar*. While the meter is taking measurements, the locator bar displays the name of the currently selected site file. In addition, the locator bar identifies the task that is currently being performed and the status of that task. For example, pressing the [PROG] key on the keypad will cause the locator bar to display "PROGRAM" and "Start" to indicate that the meter is ready to be programmed from the start of the *User Program*.

Using the Display (cont.)

At various times, one or more of the following four symbols may be displayed on the far right of the locator bar:

- %: This symbol, which is called the *pointer*, indicates that additional option bar entries are available. These options can be accessed by using the [←] and [→] keys.
- *: A flashing asterisk indicates that the Model GM868 is currently logging information. See the *Programming Manual* for instructions on creating a log file.
- S or S_L: This symbol indicates the status of the red [SHIFT] key. “S” indicates that the [SHIFT] key is activated for the next keystroke only, while “S_L” indicates that the [SHIFT] key is locked. See the next section for instructions on using the keypad.
- T: This symbol indicates that the Model GM868 is currently totalizing data.

The middle portion of the screen pane is the *prompt area*. This area displays data, graphs, and logs in measurement mode and menu prompts in programming mode. In addition, error code messages, which are described in the *Service Manual*, are displayed in the prompt area.

The lower portion of the screen pane is called the *option bar*. The option bar displays the functions assigned to the four keys immediately below the display screen ([F1]-[F4] for the left pane and [F5]-[F8] for the right pane). Press a function key to select the function listed in the option bar immediately above it. If more than four functions are available, a pointer (%) appears on the far right of the locator bar. Press the [←] or [→] keys to display the additional functions on the option bar.

For information about other symbols and text that may appear on the display screen, refer to the *Service Manual*.

Taking Measurements

The Model GM868 is capable of displaying several different variables in a variety of formats. However, this manual will only discuss the basic measurement displays in the default screen format. Refer to the *Programming Manual* for instructions on setting up alternate screen displays and see the *Service Manual* for a discussion of the diagnostic parameters listed under the DIAG option.

Note: *This section assumes that the left pane of the display screen is currently active. However, the same instructions apply equally to the right screen pane, when it is active. Just change the function keys from [F1]-[F4] to [F5]-[F8].*

For a 2-channel Model GM868, the following initial screen appears immediately upon completion of the internal checks. As an example, the display shows the measured velocity in ft/sec for Channel 1.

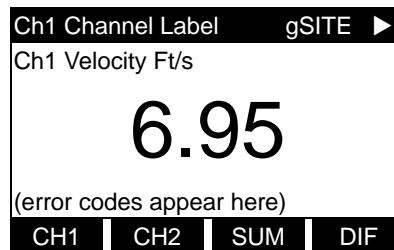

To select a different channel display option, press [F1]-[F4] (or [→] and [F1]). See Table 3-1 below for a complete description of the available options.

Table 3-1: Channel Display Options

Option Bar Choice	Description
[F1] = CH1	Channel 1
[F2] = CH2	Channel 2
[F3] = SUM	(Channel 1) + (Channel 2)
[F4] = DIF	(Channel 1) - (Channel 2)
[→] + [F1] = AVE	[(Channel 1) + (Channel 2)]/2

The following screen appears after selection of the channel mode display option for a 2-channel Model GM868 or immediately after the internal checks for a 1-channel Model GM868.

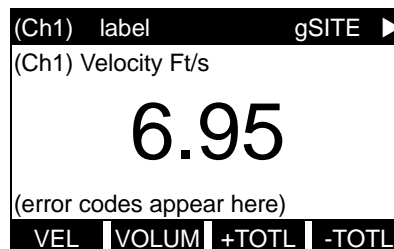

Use the [F1]-[F4], [←] and [→] keys to select the desired display parameter option. See Table 3-2 on page 3-6 for a complete description of the available options.

**Taking Measurements
(cont.)**

Note: *Ch1 (or Ch2), which is shown in parentheses above, appears only with a 2-Channel Model GM868.*

Table 3-2: Measurement Parameter Options

Option Bar Choice	Description
[F1] = VEL	Flow Velocity
[F2] = VOLUM	Volumetric Flow
[F3] = +TOTL	Forward Totalized Volume Flow
[F4] = -TOTL	Reverse Totalized Volume Flow
[→] + [F1] = TIME	Total Flow Measurement Time
[→] + [F2] = MDOT*	Mass Flow
[→] + [F3] = +MASS*	Forward Totalized Mass Flow
[→] + [F4] = -MASS*	Reverse Totalized Mass Flow
[→] + [→] + [F1] = DIAG	Diagnostic
* Available only if Mass Flow (static)? = YES	

During programming of the PIPE submenu, a Mass Flow (static)? prompt requires a response. If a YES response is given, all of the options listed in Table 3-2 above are available. However, if a NO response is given, the three options indicated do not appear and the DIAG option will appear in the [F2] position on the second option bar screen.

By following the instructions in this section, the Model GM868 can be set up to display the desired channel option (for a 2-Channel meter) and the desired measurement parameter. To utilize the more advanced display capabilities of the Model GM868, refer to the *Programming Manual* and/or the *Service Manual* for the instrument.

**Foundation Fieldbus
Communications**

Foundation Fieldbus provides a means of communicating with the flowmeter. The patent numbers which apply are 5,909,363 and 6,424,872.

This Foundation Fieldbus device supports two Analog Input (AI) blocks, which can be configured to supply the following measurements on the network (see Table 3-3 on page 3-7).

Table 3-3: Available Measurements Using Foundation Fieldbus

Channel 1	Units	Channel 2	Units	Average	Units
Ch1 Velocity	ft/s or m/s*	Ch2 Velocity	ft/s or m/s*	Avg Velocity	ft/s or m/s*
Ch1 Act Volumetric	VOL_U	Ch2 Act Volumetric	VOL_U	Avg Act Volumetric	VOL_U
Ch1 Std Volumetric	VOL_U	Ch2 Std Volumetric	VOL_U	Avg Std Volumetric	VOL_U
Ch1 Fwd Totals	TOT_U	Ch2 Fwd Totals	TOT_U	Avg Fwd Totals	TOT_U
Ch1 Rev Totals	TOT_U	Ch2 Rev Totals	TOT_U	Avg Rev Totals	TOT_U
Ch1 #Tot Digits**	none	Ch2 #Tot Digits**	none	Avg #Tot Digits**	none
Ch1 Mass Flow	MASS_U	Ch2 Mass Flow	MASS_U	Avg Mass Flow	MASS_U
Ch1 Fwd Mass Totals	MTOT_U	Ch2 Fwd Mass Totals	MTOT_U	Avg Fwd Mass Totals	MTOT_U
Ch1 Rev Mass Totals	MTOT_U	Ch2 Rev Mass Totals	MTOT_U	Avg Rev Mass Totals	MTOT_U
Ch1 #Mass Tot Digits	none	Ch2 #Mass Tot Digits	none	Avg #Mass Tot Digits	none
Ch1 Timer	sec	Ch2 Timer	sec	Avg Timer	sec
Ch1 Error Code	none	Ch2 Error Code	none	Avg Error Code	none
Ch1 SSUP	none	Ch2 SSUP	none	Avg SSUP	none
Ch1 SSDN	none	Ch2 SSDN	none	Avg SSDN	none
Ch1 Sound Speed	ft/s or m/s*	Ch2 Sound Speed	ft/s or m/s*	Avg Sound Speed	ft/s or m/s*
Ch1 Density***	see note	Ch2 Density***	see note		
Ch1 Temperature	Deg F or C*	Ch2 Temperature	Deg F or C*		
Ch1 Pressure	PRESS_U	Ch2 Pressure	PRESS_U		
<p>*Metric or English units are determined by the setup of the flowmeter.</p> <p>**Totalizer digits are available for informational purposes only. Respective totals are automatically scaled by the Tot Digits value selected in the flowmeter setup.</p> <p>***If the meter is outputting Mole Weight, the unit is "mw", otherwise it is the programmed pressure unit.</p> <p>VOL_U, TOT_U, MASS_U, MTOT_U and PRESS_U are determined by the units chosen for these measurements in the flowmeter setup. See the instrument User's Manual for the setup of these parameters.</p>					

Chapter 4

Specifications

General.....	4-1
Electrical.....	4-2
Operational	4-4
Wetted Transducer	4-4
Flowcell.....	4-5

General	The general specifications for the Model GM868 flowmeter are divided into the following categories:
Hardware Configuration	<p>Package Options:</p> <p>Standard: Epoxy-coated aluminum weatherproof Type 4X/IP66</p> <p>Optional: Stainless steel, fiberglass, explosion-proof, flameproof</p> <p>Physical:</p> <p>Size: 14.24 × 11.4 × 5.12 in. (36.2 × 29 × 13 cm)</p> <p>Weight: 11 lb (5 kg)</p>
Environmental	<p>Operating Temperature:</p> <p>-4° to 131°F (-20° to 55°C)</p> <p>Storage Temperature:</p> <p>-67° to 167°F (-55° to 75°C)</p>
Fluid Types	All acoustically conductive gases
Flow Accuracy	<p>% of Reading:</p> <p>±1% to 2% of reading typical</p> <p>Note: Accuracy depends on pipe size and other factors, such as 1-path or 2-path measurement. Accuracy to ±0.5% of reading may be achievable with process calibration.</p>
Range	<p>Bidirectional:</p> <p>-150 to -0.1 ft/s (-46 to -0.03 m/s)</p> <p>0.1 to 150 ft/s (0.03 to 46 m/s)</p>
Rangeability	1500:1
Repeatability	±0.2% to 0.5% of reading
	<p>Note: Specifications assume a fully developed flow profile, with a typical straight run of pipe 20 diameters upstream and 10 diameters downstream, and flow velocity greater than 3 ft/s (1m/s). Accuracy depends on pipe size and other factors.</p>
Response Time	<p>For a 0–90% Step Change:</p> <p>3 seconds to within 1% of final value</p>

Electrical	The electrical specifications for the Model GM868 flowmeter are divided into the following categories:
Power Supply	Input Options: 100 to 130 VAC, 50/60 Hz with 1.0 A Slo-Blo Fuse 200 to 265 VAC, 50/60 Hz with 0.5 A Slo-Blo Fuse 12 to 28 VDC with 3.0 A Slo-Blo Fuse, $\pm 5\%$
Power Usage	20 W maximum
Operating Mode	Transit-time flow measurement for gas transducers.
European Compliance	This unit complies with EMC Directive 89/336/EEC and 73/23/EEC Low Voltage Directive (Installation Category II, Pollution Degree 2), and PED 97/23/EC for DN<25.
Input/Output	Keypad: 39-key membrane keypad with tactile feedback Display: Both single- and dual-channel models have two independent software-configurable 64 x 128-pixel LCD graphic displays Digital Interfaces: <ul style="list-style-type: none">• Standard: RS232• Optional: RS485 (multiuser)• Optional: MODBUS protocol• Ethernet TCP/IP• MODBUS TCP/IP (Ethernet) Analog Input Options: Select up to 3 boards of one of the following types: <ol style="list-style-type: none">1. <i>Analog Input Board</i> with two isolated 0/4-20 mA inputs and 24-V loop power.2. <i>RTD Input Board</i> with two isolated 3-wire RTD inputs; Span -148° to 662°F (-100° to 350°C). 100 ohms

Input/Output (cont.)

Analog Output Options:

All meters come with two isolated 0/4–20 mA current outputs (550 Ω maximum load).

Optional selection of up to 3 additional output boards, each with four isolated 0/4–20 mA outputs (1000 Ω maximum load).

Totalizer/Frequency Output Options:

Select up to 3 Totalizer/Frequency Output Boards, each with four outputs per board, 10 kHz max.

All boards allow software-selectable functioning in two modes:

Totalizer Mode: one pulse per defined unit of parameter (e.g., 1 pulse/gal).

Frequency Mode: pulse frequency proportional to magnitude of parameter (e.g., 10 Hz = 1 gpm).

Alarm Options:

Select up to 2 boards of one of the following types:

Basic Relay Board with three general purpose Form-C relays.

Hermetic Relay Board with three hermetically sealed Form-C relays.

Maximum Relay Ratings:

120 VAC AC Voltage, 28 VDC DV Voltage, 5A AC/DC Current,
60 VA AC Power, 30 W DC Power (General Purpose) or
56 W DC Power (Hermetically Sealed)

Operational

The operational specifications for the Model GM868 flowmeter are divided into the following categories:

Flow Computer (Built-in)

The flow computer has three operating modes:

1. *RUN (Normal operating mode):*
Flow velocity equations are solved and statistical data rejection techniques are employed to provide reliable and repeatable results.
2. *PARAMETER:*
Allows the operator to calibrate inputs and outputs and to display certain diagnostic information such as checksums, calculated gas sound speed, signal strength, etc.
3. *DIAGNOSTIC:*
Allows the operator to calibrate inputs and outputs and to display certain diagnostic information such as checksums, signal strength, calculated gas sound speed, etc.

Data Logging

Keypad-programmable for setting up log units, update interval, start and stop times. Memory capacity for more than 43,000 flow data points in a linear or circular log.

Display Functions

Liquid crystal graphic display shows flow in numeric or graphic format. Also displays logged data and diagnostics.

Printer Signal Output

Supports wide variety of thermal and impact printers. Output data in numeric or graphic (“strip chart”) format.

Wetted Transducer

The transducer specifications for the Model GM868 flowmeter are divided into the following categories:

Temperature Range

Standard: -58° to 302°F (-50° to 150°C)
Optional: -310° to 842°F (-190° to 450°C)

Frequencies

Standard: 33 kHz, 50 kHz, 100 kHz, 200 kHz, 500 kHz

Maximum Pressure

Standard: 0 to 2700 psig (1 to 187 bar))
Optional: 3480 psig (240 bar)

Materials

Standard: Titanium
Optional: Monel[®], Hastalloy[®] alloys

Wetted Transducer (cont.)

Connections

Cable Length:

One pair of RG62 AU coaxial cables, up to 1000 ft (330 m)

Housing Options:

Explosion-proof (Class I, Div. I, Group C & D)

Flameproof (INIEX/ISSeP certified for EEx d II C T6)

Weatherproof (Type-4X, IP65)

Type-7

Class I, Div. 2, Group A, B, C & D, Type 4X

Flowcell

The flowcell specifications for the Model GM868 flowmeter are divided into the following categories:

Spoolpiece

Process Connections:

Flanged, welded optional

Transducer Connections:

1-1/2 in., 300 lb. RF flange

600 lb. PanaPort

Cold Tap

Process Connections: NA

Transducer Connections:

PanaPort cold tap kit

Optional: ANSI flanged 150 lb. to 1500 lb.

Pipe Size & Materials

Pipe OD: 2 to 120 in. (50 to 3000 mm) NB and larger.

Materials: All metals. Consult GE for other materials.

Appendix A

CE Mark Compliance

Introduction.....A-1

Wiring.....A-1

External GroundingA-1

Introduction

For CE Mark compliance, the Model GM868 flowmeter must be wired in accordance with the instructions in this appendix.

IMPORTANT: *CE Mark compliance is required only for units intended for use in EEC countries.*

Wiring

The Model GM868 must be wired with the recommended cable, and all connections must be properly shielded and grounded. Refer to Table A-1 below for the specific requirements.

Table A-1: Wiring Modifications

Connection	Cable Type	Termination Modification
Transducer	RG62 a/u	Add metallic cable clamp from braid to chassis ground.
	Armored RG62 a/u or conduit	None - grounded using a cable gland.
Input/Output	22 AWG shielded (e.g. Baystate #78-1197)	Terminate shield to chassis ground.
	Armored conduit	None - grounded using a cable gland.
Power	14 AWG, 3 conductor, shielded (e.g. Belden #19364)	An external ground to the chassis is required.
	Armored Conduit	None - grounded using a cable gland.
Shielding	For CE compliance, power and I/O cables must be shielded. Cables are to be terminated within the cable gland at the GM868. Shielded cable is not required when installations include metal conduit.	

External Grounding

For CE Mark compliance, the electronics enclosure and the transducer fixture must each have an external ground wire attached.

Note: *If the Model GM868 is wired as described in this appendix, the unit will comply with the EMC Directive 89/336/EEC.*

Appendix B

Data Records

Option Cards InstalledB-1

Initial Setup DataB-2

Option Cards Installed

Whenever an option card is installed in one of the Model GM868's expansion slots, record the type of card and any additional setup information in the appropriate row of Table B-1 below.

Table B-1: Option Cards Installed

Slot #	Type of Option Card	Additional Setup Information
0	Analog Outputs (A, B)	
1		
2		
3		
4		
5		
6		

Initial Setup Data

After the Model GM868 flowmeter has been installed, some initial setup data must be entered via the *User Program*, prior to operation. Record that information in Table B-2 below.

Table B-2: Initial Setup Data

General Information						
Model #				Reference		
Software Vers.				Date		
Serial #				Z Dimension		
Measurement Method (1-Channel) - <i>ACTIV</i>						
Site Status	Burst			Measure Mode	Skon S/M	
Measurement Method (2-Channel) - <i>ACTIV</i>						
Channel 1				Channel 2		
Channel Status	Off	Burst		Channel Status	Off	Burst
Measure Mode	Skon	S/M		Measure Mode	Skon	S/M
System Parameters - <i>SYSTEM</i>						
1-Channel				2-Channel		
Site Label				Chan.1 Label		
Site Message				Chan. 1 Message		
System Units	English	Metric		Chan. 2 Label		
Stopwatch Total.	Auto	Manual		Chan. 2 Message		
1-Channel and 2-Channel						
Channel 1				Channel 2 (if applicable)		
Gas Equation				Gas Equation		
Vol. Units				Vol. Units		
Vol. Time Units				Vol. Time Units		
Vol. Dec. Digits				Vol. Dec. Digits		
Totalizer Units				Totalizer Units		
Tot. Dec. Digits				Tot. Dec. Digits		
If Static Density? = YES						
Mass Flow				Mass Flow		
Mass Flow Time				Mass Flow Time		
MDOT Dec. Dig.				MDOT Dec. Dig.		
Mass Totalizer				Mass Totalizer		
Mass Dec. Dig.				Mass Dec. Dig.		
Pipe/Transducer Parameters - <i>PIPE</i>						
Channel 1				Channel 2 (if applicable)		
Std. Trans. #				Std. Trans. #		
Spec. Trans. #				Spec. Trans. #		
Spec. Trans. Hz				Spec. Trans. Hz		
Spec. Trans. Tw				Spec. Trans. Tw		
<i>Note: table is continued on the next page.</i>						

Table B-2: Initial Setup Data (Continued)
Pipe/Transducer Parameters (cont.) - PIPE

Channel 1 (cont.)			Channel 2 (cont.)		
Pipe O.D.			Pipe O.D.		
Pipe Wall			Pipe Wall		
Pipe Material			Pipe Material		
Path Length (P)			Path Length (P)		
Axial Length (L)			Axial Length (L)		
Fluid Type	Air	Other	Fluid Type	Air	Other
Other/Sndspd			Other/Sndspd		
Static Density	No	Yes	Static Density	No	Yes
Fluid Density			Fluid Density		
Reynolds Corr.	Off	On	Reynolds Corr.	Off	On
Kin. Visc.			Kin. Visc.		
Cal. Factor			Cal. Factor		
Multi K-factors	Off	On	Multi K-factors	Off	On
Edit Table	No	Yes	Edit Table	No	Yes
K-factor Table			K-factor Table		
K-Factor #	Velocity	K-Factor	K Factor #	Velocity	K-Factor
1			1		
2			2		
3			3		
4			4		
5			5		
6			6		
7			7		
8			8		
9			9		
10			10		
11			11		
12			12		
13			13		
14			14		
15			15		
16			16		
17			17		
18			18		
19			19		
20			20		

Appendix C

Optional Enclosures

- Introduction.....C-1
- Rack Mount Enclosure.....C-1
- Rack Mount WiringC-1
- Rack Mount Front PanelC-2

Introduction

Upon request the Model GM868 flowmeter may be supplied in an enclosure other than the standard Type-4X enclosure described in Chapter 1, *Installation*, of this manual. Although the standard installation and wiring instructions still apply in general terms, some of the details may vary for different enclosure types. Refer to the appropriate sections of this appendix for the specific type of enclosure provided.

Rack Mount Enclosure

The Model GM868 flowmeter is available in a *rack mount* enclosure for installation in a standard 19" electronics rack. Refer to Figure C-1 on page C-3 for the dimensions of this unit. Simply slide the Model GM868 into the rack at the desired height and fasten the unit securely to the rack with four screws in the locations provided at the sides of the front panel.

After the unit has been physically mounted into the rack, proceed to the next section for instructions on wiring the meter.

Rack Mount Wiring

The rack mount Model GM868 requires exactly the same electrical connections as the standard version. However, the locations and type of connectors used for the various components are different. Refer to Figure C-2 on page C-4 and complete the following steps:

1. Wire the *power input* on the right side of the rear panel as follows:
 - a. Make sure a *fuse* (item #4) of the proper size and type is installed.
 - b. Connect the female end of the *line cord* provided to the power input receptacle (item #3).
 - c. Connect the *earth ground* screw terminal (item #2) to a ground point on the rack.
2. Wire the *transducers* as follows:
 - a. Connect the pair of cables supplied with the meter to the *Channel 1* upstream and downstream BNC transducer connectors on the left side of the rear panel.
 - b. For a 2-Channel meter, repeat the above step for the *Channel 2* transducer connectors (if the second channel is to be used).
 - c. Complete the transducer wiring in accordance with the instructions in Chapter 1, *Installation*, of this manual.

Rack Mount Wiring (cont.)

3. Wire the 0/4-20 mA *analog outputs* at the left side of the rear panel in accordance with the instructions in Chapter 1, *Installation*, of this manual.
4. Wire the *RS232 serial port* by completing the following steps:
 - a. Purchase or prepare a suitable serial cable. This cable should have a standard female DB9 connector, wired as shown in Figure C-2 on page C-4, for connection to the rear panel of the Model GM868. The other end should be as required for the external device.
 - b. Complete the serial port wiring in accordance with the instructions in Chapter 1, *Installation*, of this manual.
5. Wire any installed *option cards* using the same procedures described in Chapter 1, *Installation*, of this manual and the pin # assignments shown in Figure C-2 on page C-4.
6. Place the *power switch* (item #1) in the ON position.

The Model GM868 is now completely wired. Proceed to Chapter 2, *Initial Setup*, of this manual for further instructions.

Rack Mount Front Panel

The keypad and LCD display for the rack mount Model GM868 are located on the front panel. These items are identical in form and function to those used on the standard Type-4X enclosure, but the layout is somewhat different.

Refer to Figure C-3 on page C-5 for the front panel layout of the rack mount Model GM868 and follow the standard procedures detailed in the main body of this manual.

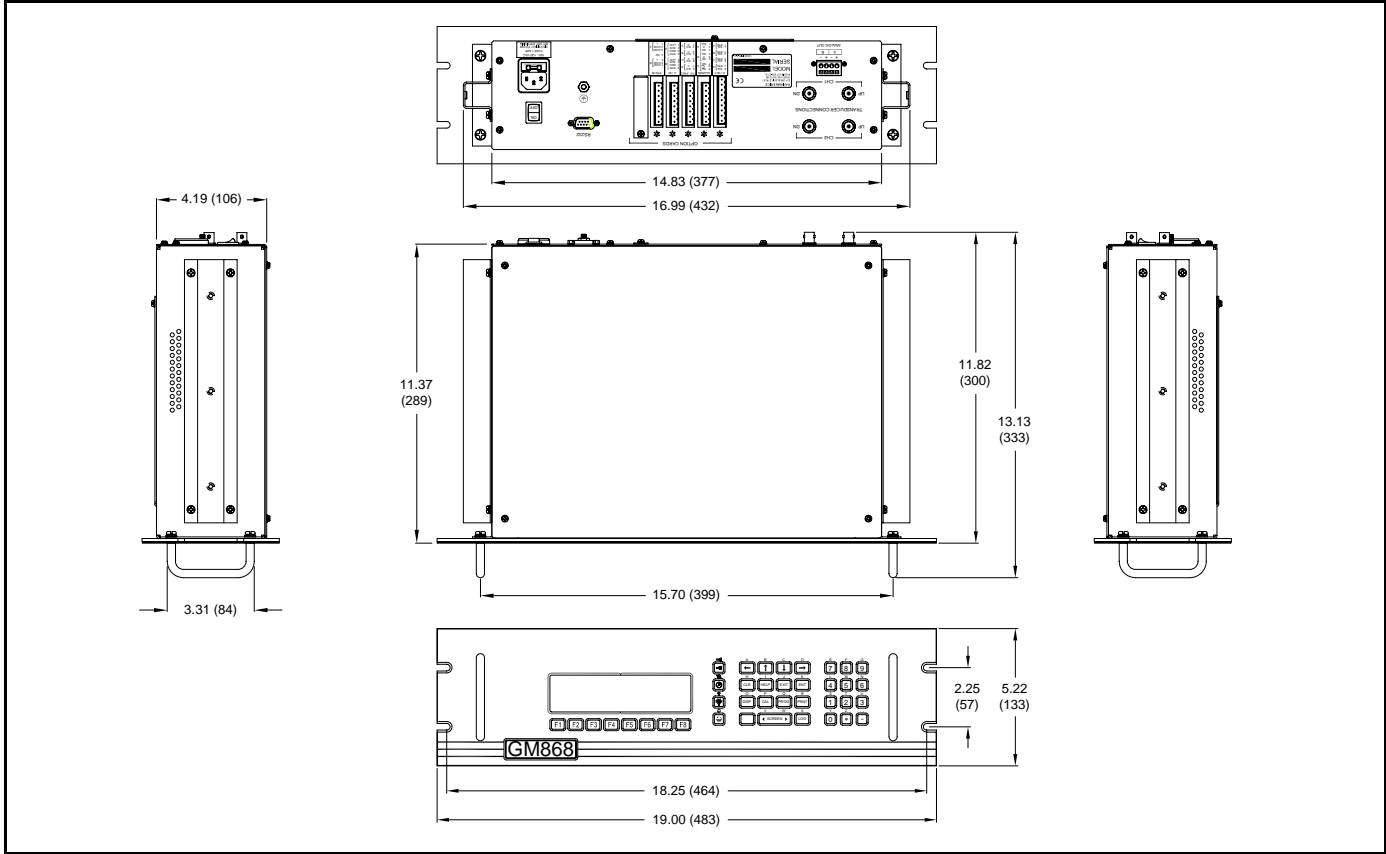

Figure C-1: Model GM868 Rack Mount Enclosure (ref. dwg #712-1078)

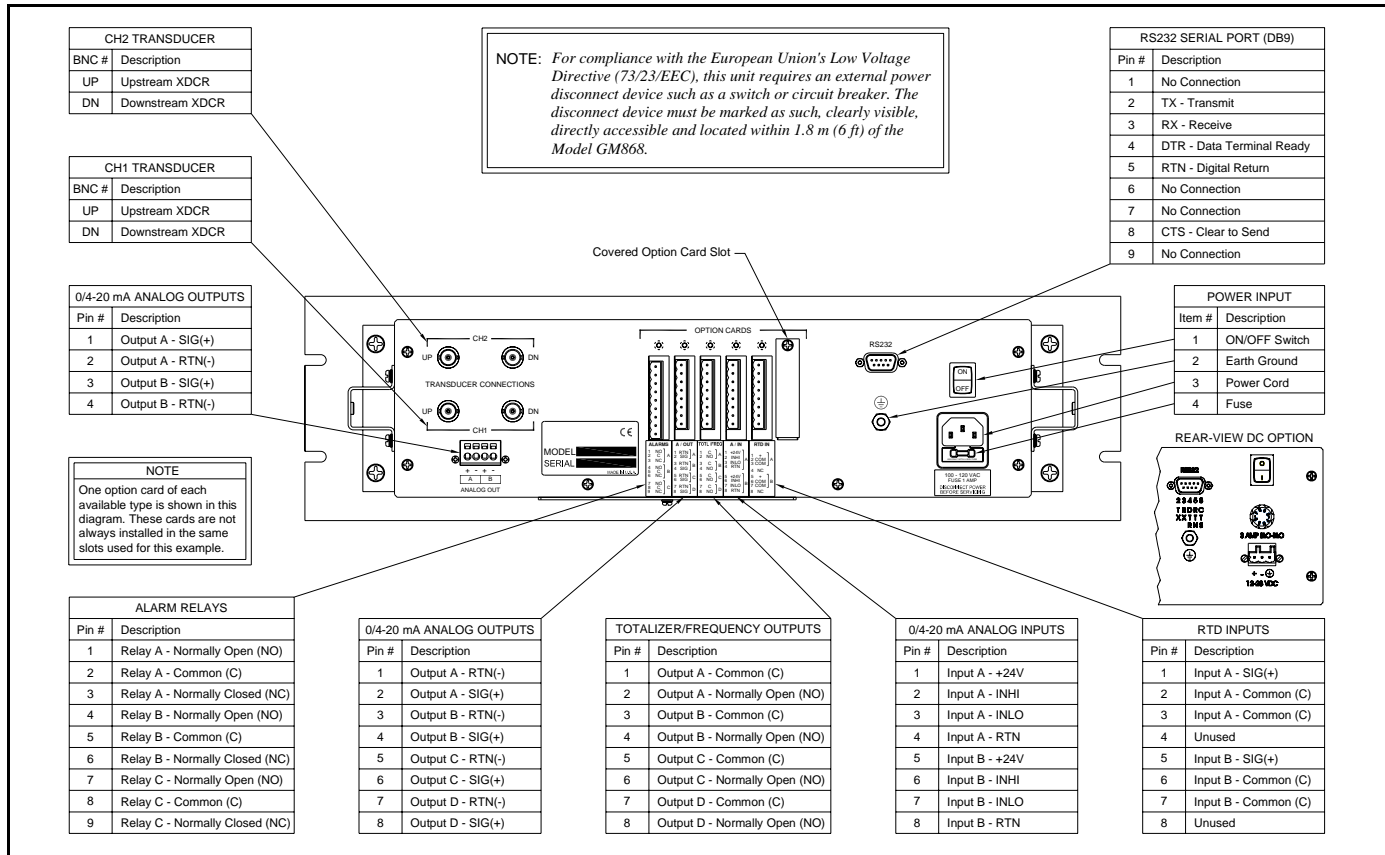

Figure C-2: Model GM868 Rock Mount Enclosure - Wiring Diagram

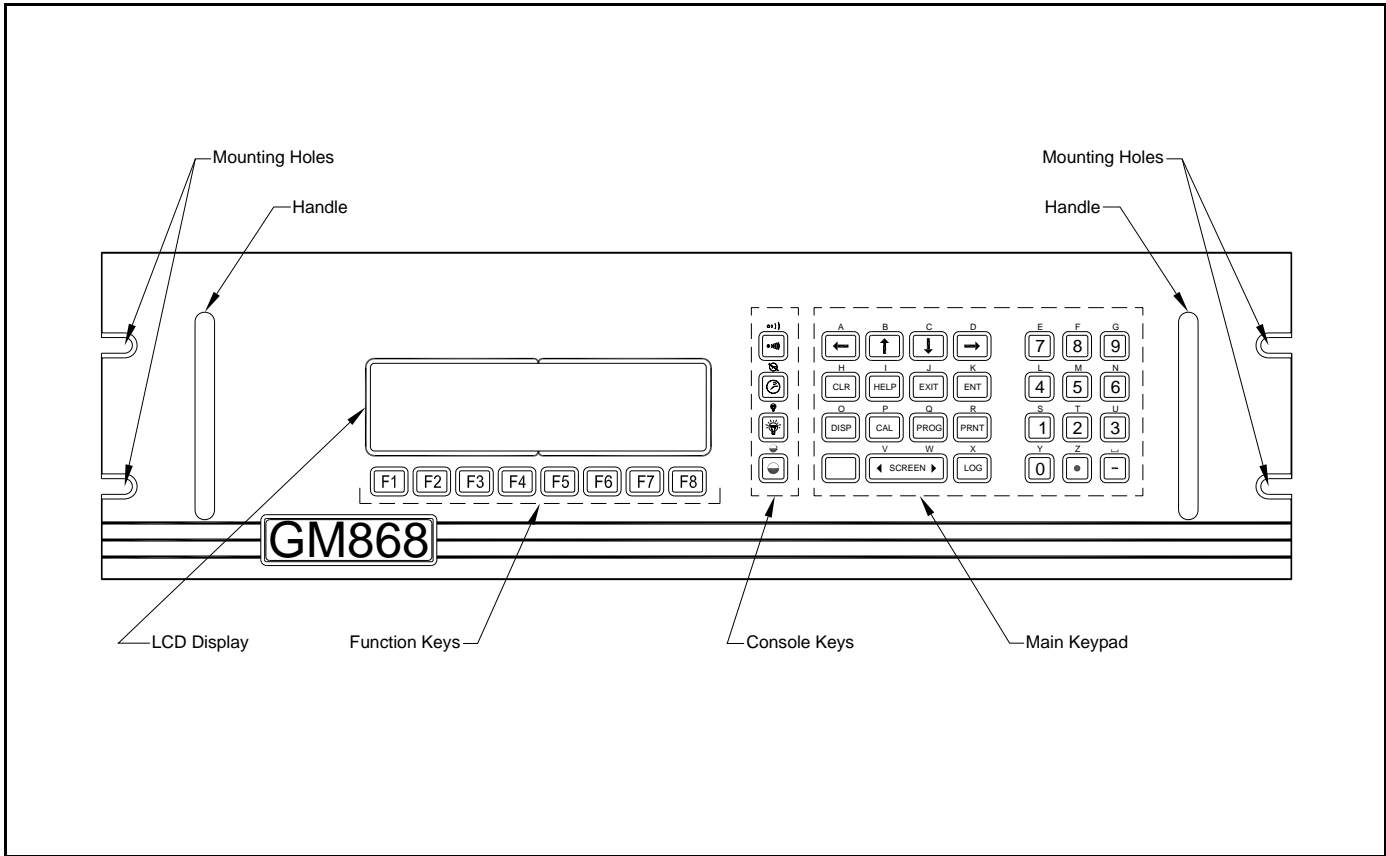

Figure C-3: Model GM868 Rack Mount Enclosure - Front Panel Layout

Appendix D

Measuring P and L Dimensions

Introduction.....D-1

Measuring P and L DistancesD-1

Introduction

When programming the PIPE menu of the Model GM868's *User Program*, the *path length* (P) and the *axial dimension* (L) must be entered. These parameters are determined by measurements on the actual transducer installation, with P equal to the face-to-face distance between the transducers and L equal to the axial distance between the centers of the transducer faces.

The accuracy of the programmed P and L values is critical to precise flow rate measurements. If GE supplies the flowcell for the system, the correct values will be included in the documentation supplied with the unit. For transducers installed on an existing pipe (see Figure D-4 on page D-2), P and L must be measured at the site. This appendix provides instructions for properly determining these dimensions.

Measuring P and L Distances

Whenever possible, physically measure the face-to-face distance (P) and the axial distance (L) between the centers of the flat faces of the transducers. Refer to Figure D-4 on page D-2 for an illustration of the proper distances to measure in a typical installation.

In some situations only one of the required distances can be directly measured. When this happens, a knowledge of the installation angle (θ) of the transducers, permits the second distance to be calculated from Equation D-1 below:

$$\cos \theta = \frac{L}{P} \quad (\text{D-1})$$

As an example, assume that the transducer installation angle is known to be 45° and the L distance is measured to be 10.00 inches. Then, the P distance is calculated to be $P = 10.00/0.707 = 14.14$ inches.

With a Bias 90° transducer installation, it sometimes happens that the only known parameters are the transducer angle (θ) and the centerline distance between the transducer bodies (CL). In these cases, it is still possible to calculate both P and L by combining Equation D-1 above with Equation D-2 below (see Figure D-4 on page D-2):

$$P = CL - 1.2 \quad (\text{D-2})$$

Standard GE 90° transducers have the face offset from the centerline of the body by 0.6 inches. Thus, a pair of transducers has a total offset of 1.2 inches, as indicated in Equation D-2 above. For example, suppose that the transducer installation angle is 30° and CL is measured to be 12.00 inches. Then, $P = 12.00 - 1.2 = 10.80$ inches and $L = 10.80 \times 0.866 = 9.35$ inches.

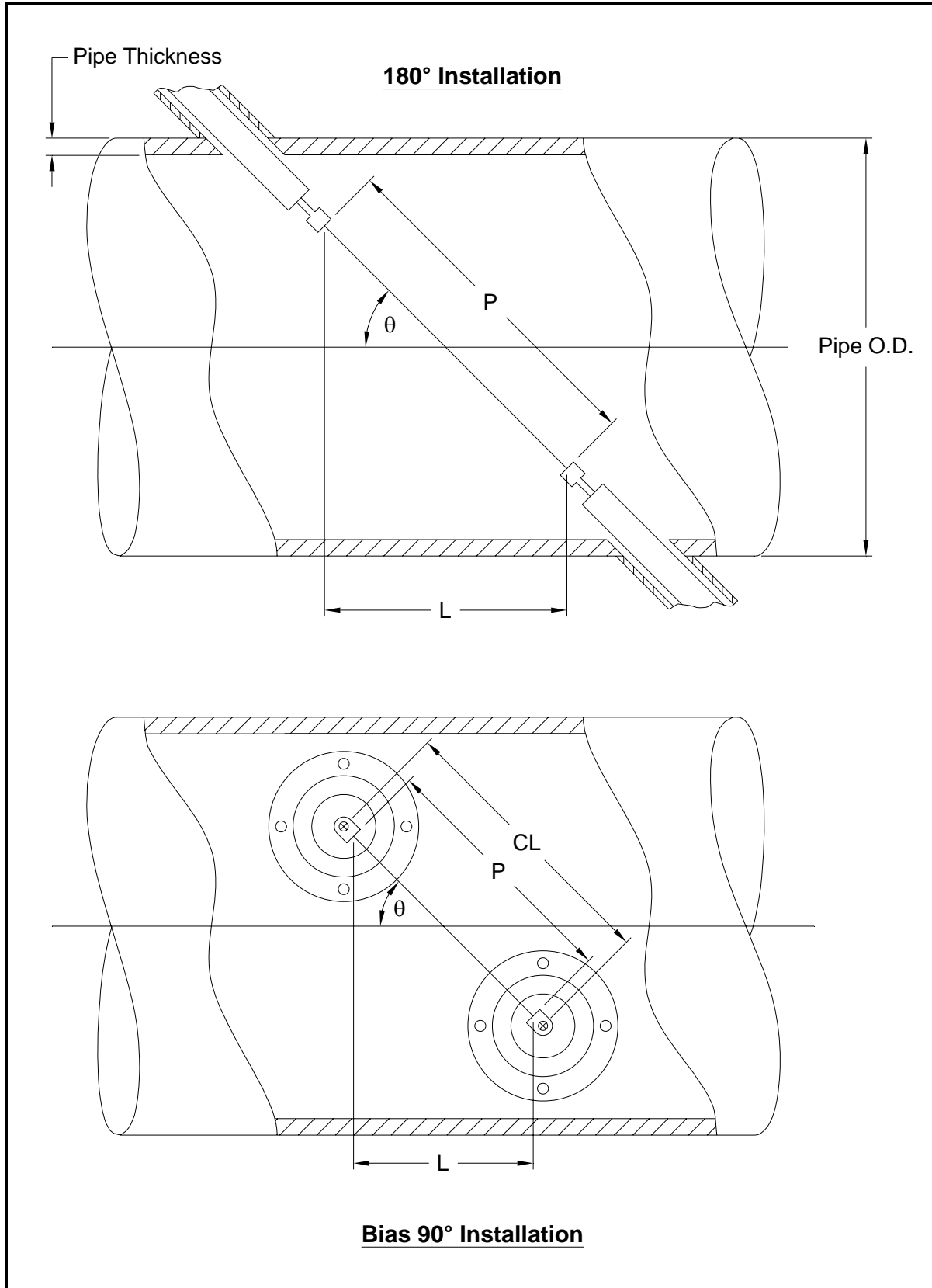

Figure D-4: Top View of Transducer Installations

Index

- A**
- Abbreviations, Volumetric Units 2-5
 - ACTIV Submenu 2-3
 - Alarms Option Card
 - Connecting 1-14
 - Fail-Safe Operation 1-14
 - Relay Ratings 4-3
 - Analog Inputs Option Card
 - Connecting 1-15
 - Pin Assignments 1-15
 - Rating 1-15
 - Ratings 4-2
 - Analog Outputs (Slot 0)
 - Connecting 1-10
 - Analog Outputs Option Card
 - Connecting 1-17
 - Axial Dimension D-1
- C**
- Cable
 - Serial Port 1-10
 - Transducers 1-3, 1-9
 - CE Mark Compliance 1-1, 1-6, 1-7, 1-9, A-1
 - Channel Label 2-5
 - Channel Message 2-5
 - Connecting
 - See Part Name
 - Connectors, Electrical 1-6
- D**
- Display
 - Channel Mode Options 3-5
 - Components 3-3
 - Data 3-2
 - Locator Bar 3-3
 - Locator Bar Symbols 3-4
 - Measurement Mode 3-2
 - Metric or English 2-4
 - Option Bar 3-3
 - Parameter Options 3-6
 - Pointer 3-3
 - Prompt Area 3-3
 - Selecting 3-3
 - Using 3-3
- E**
- Electrical Connectors 1-6
 - Electronics Console
 - Description 1-2
 - Mounting 1-6
 - Ethernet, Wiring the 1-12
- F**
- Fieldbus Network 1-13
 - Connections 1-13
 - Flowcell
 - Description 1-2
 - Installing 1-3
 - Function Keys 3-4
 - Fuse Ratings 4-2
- I**
- Initial Setup
 - Data Table B-2
 - Minimum Required 2-1
 - Input Voltage 1-7
 - Internal Tests 3-2
- K**
- Kinematic Viscosity 2-8
- L**
- Lightning Protector, Connecting 1-9
 - Locator Bar 3-3
 - LVD Shroud 1-6
 - LVD Statement 1-2
- M**
- Measurements
 - Displaying 3-2, 3-5
 - Parameter Options 3-6
 - Taking 3-2, 3-5
 - MODBUS/TCP, Wiring the 1-12

Index (cont.)

T

Temperature Transmitter	
Installing	1-5
Location	1-3
RTD	1-5
Terminal Block	
Analog Outputs - I/O	1-10
Power - TB1	1-7
Serial Port - RS232	1-10
Transducers - CH1/CH2	1-9
Totalizer/Frequency Option Card	
Connecting	1-16
Transducer	
Special	2-7
Transducers	
180° Installation	D-1
Axial Dimension	D-1
Bias 90° Installation	D-1
Cables	1-3, 1-9
Connecting	1-9
Installation Angle	D-1
Location	1-2
Path Length	D-1
Transmitter	
See Temperature or Pressure Transmitter	

U

Unpacking	1-1
User Program	
ACTIV Submenu	2-3
Entering	2-2
Exiting	2-9
Navigating	2-1

V

Voltage, Input	1-7
Volumetric Units	
Abbreviations	2-5
Selecting	2-5
Table of Options	2-5

W

Wiring	
CE Mark Compliance	A-1
Foundation Fieldbus	1-13
Option Card	See Card Name
Terminal Block	See Block Name

We,

Panametrics Limited
Shannon Industrial Estate
Shannon, County Clare
Ireland

declare under our sole responsibility that the

DF868 Liquid Ultrasonic Flowmeter
GF868 Flare Gas Ultrasonic Flowmeter
GM868 Multi-Purpose Gas Ultrasonic Flowmeter
GN868 Natural Gas Ultrasonic Flowmeter
GS868 Steam Mass Ultrasonic Flowmeter

to which this declaration relates, are in conformity with the following standards:

- EN 61326:1998, Class A, Annex A, Continuous Unmonitored Operation
- EN 61010-1:1993 + A2:1995, Overvoltage Category II, Pollution Degree 2

following the provisions of the 89/336/EEC EMC Directive and the 73/23/EEC Low Voltage Directive.

The units listed above and any transducers supplied with them (spoolpieces are addressed under a separate declaration of conformity) do not bear CE marking for the Pressure Equipment Directive, as they are supplied in accordance with Article 3, Section 3 (sound engineering practices and codes of good workmanship) of the Pressure Equipment Directive 97/23/EC for DN<25.

Shannon - June 1, 2002

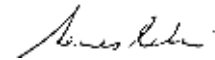

Mr. James Gibson
GENERAL MANAGER



CERT-DOC-H4



August 2004

Nous,

Panametrics Limited
Shannon Industrial Estate
Shannon, County Clare
Ireland

déclarons sous notre propre responsabilité que les

DF868 Liquid Ultrasonic Flowmeter
GF868 Flare Gas Ultrasonic Flowmeter
GM868 Multi-Purpose Gas Ultrasonic Flowmeter
GN868 Natural Gas Ultrasonic Flowmeter
GS868 Steam Mass Ultrasonic Flowmeter

relatif à cette déclaration, sont en conformité avec les documents suivants:

- EN 61326:1998, Class A, Annex A, Continuous Unmonitored Operation
- EN 61010-1:1993 + A2:1995, Overvoltage Category II, Pollution Degree 2

suivant les règles de la Directive de Compatibilité Electromagnétique 89/336/EEC et de la Directive Basse Tension 73/23/EEC.

Les matériels listés ci-dessus ainsi que les transducteurs pouvant être livrés avec (les manchettes faisant l'objet d'une déclaration de conformité séparée) ne portent pas le marquage CE de la directive des équipements sous pression, car ils sont fournis en accord avec la directive 97/23/EC des équipements sous pression pour les DN<25, Article 3, section 3 qui concerne les pratiques et les codes de bonne fabrication pour l'ingénierie du son.

Shannon - June 1, 2002

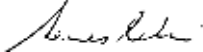
Mr. James Gibson
DIRECTEUR GÉNÉRAL



CERT-DOC-H4



August 2004

Wir,

Panametrics Limited
Shannon Industrial Estate
Shannon, County Clare
Ireland

erklären, in alleiniger Verantwortung, daß die Produkte

DF868 Liquid Ultrasonic Flowmeter
GF868 Flare Gas Ultrasonic Flowmeter
GM868 Multi-Purpose Gas Ultrasonic Flowmeter
GN868 Natural Gas Ultrasonic Flowmeter
GS868 Steam Mass Ultrasonic Flowmeter

folgende Normen erfüllen:

- EN 61326:1998, Class A, Annex A, Continuous Unmonitored Operation
- EN 61010-1:1993 + A2:1995, Overvoltage Category II, Pollution Degree 2

gemäß den Europäischen Richtlinien, Niederspannungsrichtlinie Nr.: 73/23/EG und EMV-Richtlinie Nr.: 89/336/EG.

Die oben aufgeführten Geräte und zugehörige, mitgelieferte Schallwandler (Messrohre werden in einer separaten Konformitätserklärung behandelt) tragen keine CE-Kennzeichnung gemäß der Druckgeräte-Richtlinie, da sie in Übereinstimmung mit Artikel 3, Absatz 3 (gute Ingenieurpraxis) der Druckgeräte-Richtlinie 97/23/EG für DN<25 geliefert werden.

Shannon - June 1, 2002

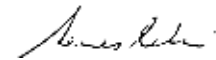

Mr. James Gibson
GENERALDIREKTOR



CERT-DOC-H4



August 2004



USA

1100 Technology Park Drive
Billerica, MA 01821-4111
Web: www.gesensing.com

Ireland

Sensing House
Shannon Free Zone East
Shannon, County Clare
Ireland

