

## Features

- Rapid speed of response to both wet up and dry down conditions comparable to high-end analyzers
- Accurate moisture measurement from 0 to 100 ppb<sub>v</sub>
- Innovative measurement technique using newly patented aluminum oxide sensor technology
- Simplified, compact “flow-through” tee sample cell design
- Stainless steel VCR fittings
- CE certification and UL 508
- Easy-to-read large display
- Analog and digital outputs for full integration
- Compatible with PanaView™ interface software
- Installs out of the box in minutes

## Applications

HygroTrace uses a newly patented technique to provide accurate and reliable measurement at trace moisture levels. Combining over 70 years of experience in aluminum oxide sensor technologies by Panametrics and General Eastern, this robust sensor provides the sensitivity and speed of response in the ppb<sub>v</sub> range matched only by traditionally expensive analyzers.

- Ultra high purity (UHP) nitrogen and argon
- Cylinder, tank and truck filling applications
- Gas distribution systems in semiconductor fabrication facilities
- Tool and machine manufacturers

---

# HygroTrace

## Ultra-Low Moisture Transmitter

HygroTrace is a new addition to the extensive Panametrics and General Eastern product lines for ultra-low PPB moisture applications.



# GE Sensing

HygroTrace is a compact moisture transmitter designed to meet the technical requirements of the semiconductor industry. HygroTrace offers accuracy not commonly found in a transmitter and the speed of response of a full-featured analyzer at a fraction of the cost. Now you can monitor multiple points of measurements for less than the cost of one analyzer and without installation constrictions. HygroTrace's unique and innovative sensor measurement technique responds to wet up and dry down conditions in minutes, minimizing moisture intrusion in your process.

HygroTrace is designed for installation where space is at a premium. The sensor is mounted on a "flow-through" tee sample cell that can be installed directly into the process stream or on a bypass leg of a gas distribution network. No custom machining is required. The sample cell uses a small volume sample and is composed of components that minimize moisture adsorption that adversely effects measurements.

HygroTrace features an integral backlit display to provide easy viewing and a keypad to configure the display, outputs, and other user functions and diagnostics. The RS485 interface enables the transmitter to be fully integrated into existing systems for OEM applications and networks.

## Patented Sensor Measurement Technique

Traditionally, aluminum oxide sensors have not been widely used for measuring trace levels of moisture (<100 ppb<sub>v</sub>) due to sensor response time and calibration stability at these levels. However, aluminum oxide sensors offer many benefits to users, including a wide measurement range, simple installation and minimal temperature, pressure or gas composition effects. By further investigating aluminum oxide moisture sensor technology, GE Sensing has developed a new sensor, manufactured with semiconductor techniques, that applies a temperature pulse to 'dry' the sensor. Then the re-adsorption rate is measured while holding a constant sensor temperature. This measurement is proportional to the moisture concentration in the sample gas.



The short measurement window length effectively filters the long time constant variations in hardware and sensor response. Only short time constant, oxide surface adsorption contributes to the measurement. The end product is a robust thin film sensor design that provides the sensitivity and response time needed to effectively measure parts per billion levels of moisture.

## Wet Up Response

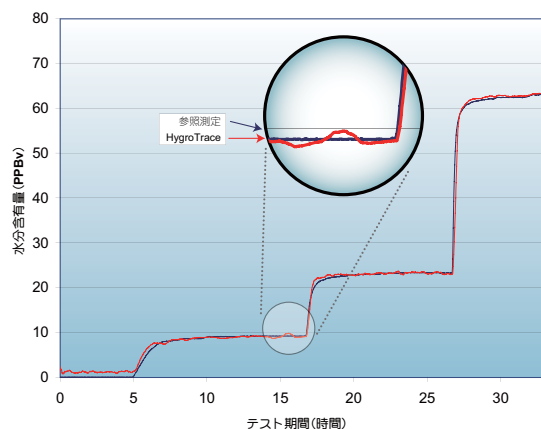

## Dry Down Response

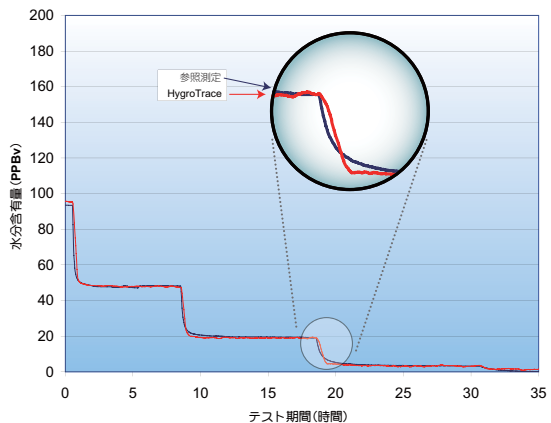

# HygroTrace Specifications

## Measurement Range

0 to 100 ppb<sub>v</sub>, with trend indication beyond the calibrated range

## Compatible Gases

Nitrogen and argon

## Process Gas Temperature Range

14°F to 95°F (-10°C to 35°C)

## Storage Temperature

-40°F to 158°F (-40°C to 70°C)

## Warm-Up Time

Meets specified accuracy within 24 hours, after sensor exposure <72 hours @ 25°C and 60% RH

## Calibrated Accuracy @ 77°F (25°C)

±20% of reading or ±5 ppb<sub>v</sub>, whichever is greater

## Response Time

Less than 20 minutes for 95% of 25 ppb<sub>v</sub> step change

## Electrical

### Power

20 to 28 VDC, 20 watts

Output: 4 to 20 mA analog, RS485 digital

Output Resolution: 14 bits

### Display

128 X 64 LED backlit LCD

Display one measurement parameter and diagnostics

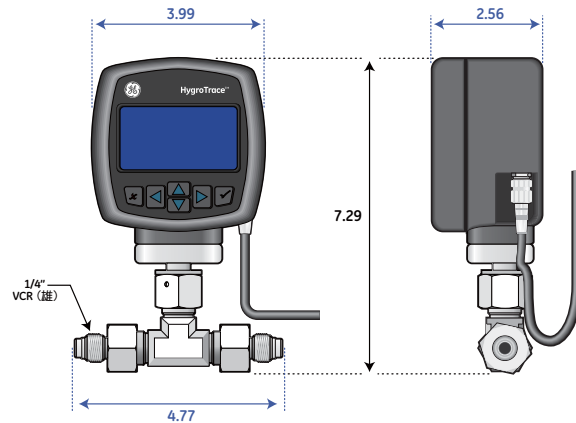

## Mechanical

### Sample Connection

In-line flow, ¼ inch (6.35mm) VCR process connection

### Sample Flow Rate

1 to 4.3 SCFH (0.5 to 2 SLM)

### Operating Pressure

0 to 100 psig (0 to 6,9 bar)

### Proof Pressure

3000 psig (207 bar)

### Enclosure

Aluminum construction; black color; powder coated finish

### Dimensions: (h x w x d)

Overall: 7.3 in x 4.6 in x 2.5 in

(185 mm x 117 mm x 63.5 mm)

Weight: 2.5 lbs (1.13 g)

### Certifications

Complies with EMC Directive 89/336/EEC and PED 97/23/EC for DN < 25

UL 508

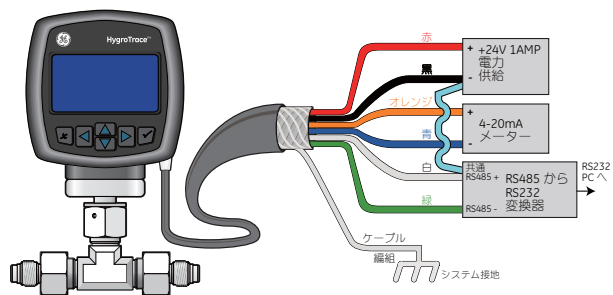

## Moisture Sensor

### Sensor Type

Thin-film aluminum oxide moisture sensor

### Calibration

Each sensor is individually computer-calibrated against known moisture concentrations

### Calibration Interval

Sensor recalibration by GE is recommended every 6 to 12 months depending on application



©2007 GE. All rights reserved.  
920-382D\_E

All specifications are subject to change for product improvement without notice. GE® is a registered trademark of General Electric Co. Other company or product names mentioned in this document may be trademarks or registered trademarks of their respective companies, which are not affiliated with GE.