

Apollo™

Operating Manual



1	Safety and Warranty Information	1-1
1.1	Safety Information	1-2
1.2	Software	1-2
1.3	Defects/Errors and Exceptional Stresses.....	1-3
1.4	Important Information on Eddy Current Testing	1-3
1.5	Pre-Conditions for Testing with Eddy Current Testing.....	1-3
1.6	Operator Training.....	1-4
1.7	Warranty.....	1-5
2	Introduction and Equipment Box	2-1
2.1	Apollo™	2-2
2.2	Equipment Box.....	2-2
2.3	Front of Equipment Box	2-4
3	Connectors.....	3-1
3.1	Probe Connectors	3-2
3.2	REF Connector	3-5
3.3	Encoders Connection.....	3-7
3.4	Digital Connector	3-8
3.5	Analog Connector.....	3-9
3.6	SI-Master Connector.....	3-9
3.7	SI-485 Connector	3-10
3.8	Audio Connector.....	3-11
3.9	Video Connector.....	3-11
3.10	Monitor Connector	3-12
3.11	Keyboard Connector	3-13
3.12	Mouse Connector.....	3-13
3.13	USB Connector	3-14
3.14	Ethernet Connector.....	3-14
3.15	Power Connector	3-15
4	Connections	4-1
4.1	Coil Connection.....	4-2
4.2	Connection.....	4-4
5	Maintenance	5-1
5.1	Replacing the Fuse.....	5-2
5.2	Change of Filter.....	5-3
6	Quick Troubleshooting Guide	6-1
6.1	Trouble Shooting	6-2
7	Specifications.....	7-1
7.1	Specifications.....	7-2
8	WEEE and Service Centers	8-1

1 Safety and Warranty Information

1.1 Safety Information

The Apollo™ was designed and tested in accordance with EN61010 Part 1, 2002 Safety Requirement for Electrical and Measuring, Control and Laboratory Use.

Before powering or operating this instrument, the following safety information should be carefully read. This operating manual should be kept in a safe place for reference.

1.2 Software

Software is never completely free from errors. Before using any software controlled test equipment, please make sure that the required functions operate correctly perfectly in the intended combination. If you have any questions about the use of your test equipment, please contact your nearest representative of GE Inspection Technologies.

1.3 Defects/Errors and Exceptional Stresses



ATTENTION

If you have reason to believe that safe operation of your Apollo is no longer possible, you must disconnect the instrument.

DO NOT OPERATE IF:

- Instrument is visibly damaged.
- Instrument no longer operates correctly.
- Instrument has been stored for a prolonged period in adverse conditions.
- Instrument has been subjected to heavy stresses during transportation.

1.4 Important Information on Eddy Current Testing

Please read the following information before using your Apollo. It is important that you understand and utilize this information to avoid any operator errors that might lead to false test results. This could result in personal injuries or damage to property.

1.5 Pre-Conditions for Testing with Eddy Current Testing

This operating manual contains essential information on how to operate your test equipment. In addition, there are a number of additional factors that affect test results, which are beyond the scope of this operating manual. This operating manual only covers the most important factors for a safe and reliable Eddy Current inspection, and operator training.

1.6 Operator Training



ATTENTION

The operation of an Eddy Current test device requires proper training in Eddy Current test methods and equipment usage.

As a general rule, effective use of eddy current equipment for new applications requires the following:

- An understanding of the principles of Eddy Current testing, particularly aspects which may limit detection of flaws such as depth of penetration and the way in which different probe configurations respond to different flaw types.
- An understanding of other NDT and inspection procedures which may be more appropriate or be required to verify the results.
- Knowledge of the application, i.e. the way in which the part being tested is manufactured or stressed in use and the probable flaw mechanisms.
- A good working knowledge of the equipment to be used plus a written technique to be followed in performing the inspection.

1.7 Warranty

Limited Service Warranty:

If, through our negligence, GE Inspection Technologies directly caused physical damage to your equipment while the equipment is in the sole custody and control of GE Inspection Technologies, we shall choose at our opinion either to repair the damage or replace the damaged portion of the equipment at our own expense, or to indemnify and hold you harmless for such physical damage to the Equipment. EXCEPT FOR THE WARRANTY SET IN THIS PARAGRAPH, GEIT EXPRESSLY DISCLAIMS ALL WARRANTIES AND REPRESENTATION OF ANY KIND WITH RESPECT TO OUR SERVICES OR THE INFORMATION CONTAINED IN ANY REPORTS THAT WE ISSUE TO YOU, WHETHER EXPRESSED OR IMPLIED, INCLUDING ANY IMPLIED WARRANTIES OF MERCHANTABILITY, FITNESS FOR A PARTICULAR PURPOSE, NON-IN-FRINGEMENT, TITLE AND WARRANTIES ARISING FROM COURSE OF PERFORMANCE, COURSE OF DEALING OR TRADE USAGE.

2 Introduction and Equipment Box

2.1 Apollo™

The Apollo is the most advanced eddy current system currently offered by GE Inspection Technologies. Its modularity allows it to be adaptable depending on the characteristics of the test being performed as well as those of the user.

The Apollo tester is the industrial version of the Apollo system, capable of supporting up to 8 coils. With minimal dimensions, the unit incorporates the Eddy Current acquisition system, Siroco-Inside machine control system, control and acquisition computer along with optional audio and video systems.

2.2 Equipment Box

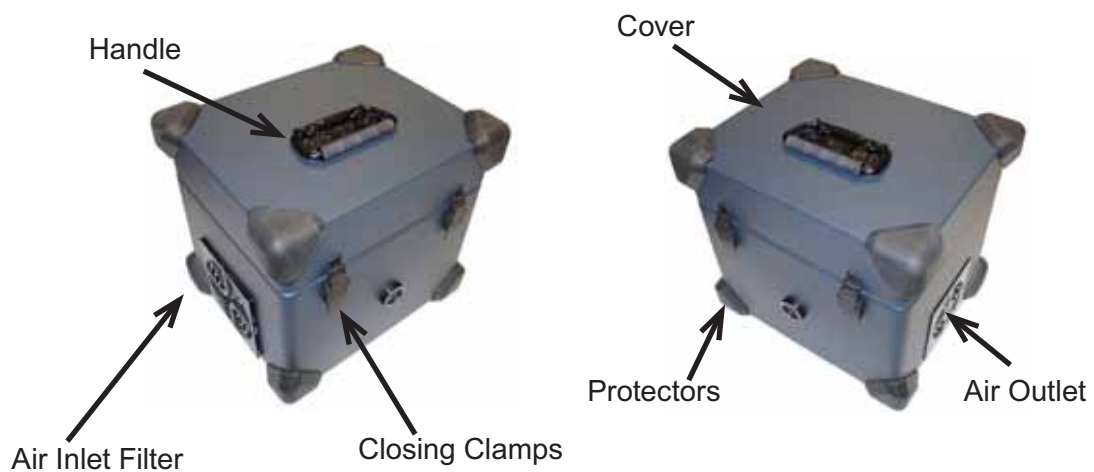

Handle	Is used to transport the instrument.
Cover	Protects the front panel of the instrument, and all connectors.
Closing Clamps	Attaches the protective cover to the box.
Air Inlet Filter	Filters the air entering the tester via the fan. (The air inlet should never be covered.)
Protectors	Protects the corners of the equipment.
Air Outlet	Outlet air vented from the equipment. (This should never be covered.)



2.3 Front of Equipment

The front of the tester allows easy access to all connections. The front panel is divided into five functional groups, as shown in the following photographs.



EC Zone



Siroco-Inside Zone



Audio-Video Zone



Computer Zone



Power Zone

EC Zone (Pink)	Contains all the connectors and LED's associated with the eddy current acquisition process: PROBE, REF, ENCODERS, ANALOG, DIGITAL and LED indicators Rx1 to Rx4.
Siroco-Inside Zone (Tan)	Contains the connectors associated with the Siroco-Inside mechanical: SI-MASTER, SI-485, ENCODERS.
Audio-Video Zone (Yellow)	Audio and video connectors: AUDIO, VIDEO.
Computer Zone (Green)	Typical computer connectors: MONITOR, KEYBOARD, MOUSE, USB, ETHERNET.
Power Zone (Blue)	Connectors, buttons and LED indicators controlling equipment power.

The functionality of each of the items on the front panel is described below. In the following figure a number is assigned to each item with the color reflecting the group (zone) to which it belongs

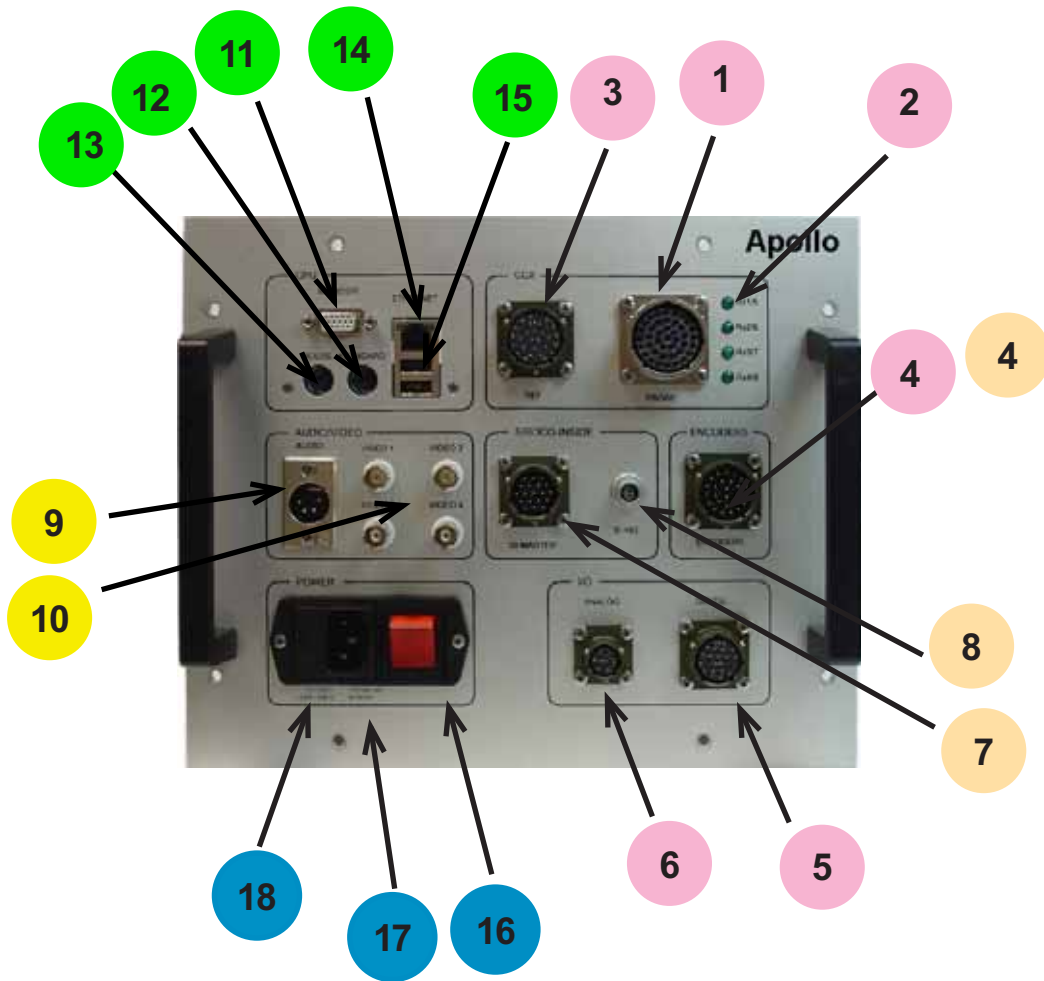

1	PROBE	Connector for Eddy Current coils.
2	Rx1/5 Rx2/6 Rx3/7 Rx4/8	Eddy Current receiver status LED indicators. This has two working modes: Acquisition: when flashing it indicates that the corresponding receiver is acquiring data from the coil. Outside acquisition: a LED sweep is performed, indicating that the system is ready for operation.
3	REF	Connector with the outputs from generators 3 to 8.
4	ENCODERS	Encoder connectors. The encoders are used for the Eddy Current and Siroco-Inside modules.
5	DIGITAL	Connectors associated with digital inputs and outputs.
6	ANALOG	Connectors associated with analog inputs.
7	SI-MASTER	Connector for control and auxiliary signals for the Siroco-Inside control module (the optional SI-MASTER card needs to be installed).
8	SI-485	Connector for the Siroco-Inside communications bus (the optional SI-MASTER card needs to be installed).
9	AUDIO	Input for microphone and audio output (the optional audio card needs to be installed).
10	VIDEO1..4	Video inputs (the optional video acquisition card needs to be installed).
11	MONITOR	Output for a monitor.
12	KEYBOARD	Keyboard input.
13	MOUSE	Mouse input.
14	ETHERNET	Ethernet communications port.
15	USB	USB 1.1. Communications port.
16	ON/OFF	Equipment on/off button. When the equipment is ON, this button is lit in red.
17	POWER	110/220 V AC power input.
18	FUSE	Fuse housing.

3.1 Probe Connector

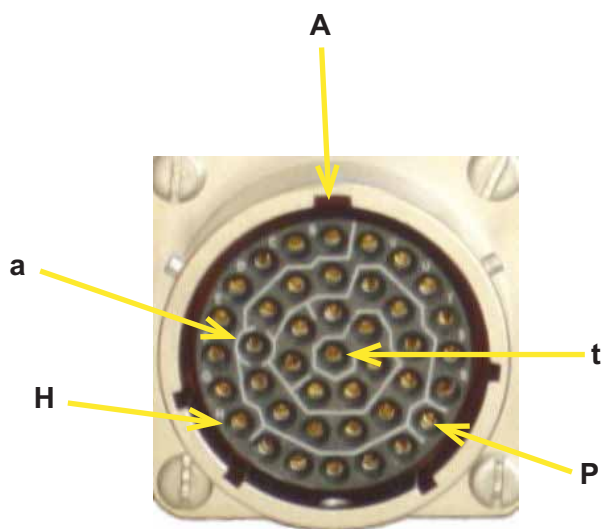

	Reference	Manufacturer	Description
1	MS3470L20-41S	Matrix	Panel female connector
2	MS3476L20-41P	Matrix	Aerial male connector
3	360AS001C2008M5	Glenair	Rear for aerial connector

Pin	Signal	Description
A	G1_BOB1	Direct output 1 of generator 1
B	G1_BOB11	Output 1 from generator 1 via 100Ω resistance 1.
C	G1_BOB12	Output 1 from generator 1 via 100Ω resistance 2.
D	G1_BOB21	Output 2 from generator 1 via 100Ω resistance 1.
E	G1_BOB22.	Output 2 from generator 1 via 100Ω resistance 2.
F	G1_BOB31	Output 3 from generator 1 via 100Ω resistance 1.
G	G1_BOB32	Output 3 from generator 1 via 100Ω resistance 2.
H	G1_BOB41	Output 4 from generator 1 via 100Ω resistance 1.
J	G1_BOB42	Output 4 from generator 1 via 100Ω resistance 2.
K	—	
L	GND	Ground.
M	G2_BOB1	Direct output 1 of generator 2.
N	G2_BOB11	Output 1 from generator 2 via 100Ω resistance 1.

Pin	Signal	Description
P	G2_BOB12	Output 1 from generator 2 via 100Ω resistance 2
R	G2_BOB21	Output 2 from generator 2 via 100Ω resistance 1.
S	G2_BOB22.	Output 2 from generator 2 via 100Ω resistance 2
T	G2_BOB31.	Output 3 from generator 2 via 100Ω resistance 1
U	G2_BOB32	Output 3 from generator 2 via 100Ω resistance 2.
V	G2_BOB41	Output 4 from generator 2 via 100Ω resistance 1.
W	G2_BOB42	Output 4 from generator 2 via 100Ω resistance 2.
X	GND	Ground
Y	-15v	Auxiliary negative power
Z	IN1R1	Input 1 of receiver 1.
a	IN2R1	Input 2 of receiver 1.
b	IN1R2	Input 1 of receiver 2.
c	IN2R2	Input 2 of receiver 2.
d	IN1R3	Input 1 of receiver 3.
e	IN2R3	Input 2 of receiver 3
f	IN1R4	Input 1 of receiver 4.
g	IN2R4	Input 2 of receiver 4.
h	GND	Ground.
i	IN1R5	Input 1 of receiver 5.
j	IN2R5	Input 2 of receiver 5.
k	IN1R6	Input 1 of receiver 6.
m	IN2R6	Input 2 of receiver 6
n	IN1R7	Input 1 of receiver 7.
p	IN2R7	Input 2 of receiver 7.
q	IN1R8	Input 1 of receiver 8.
r	IN2R8	Input 2 of receiver 8.
s	GND	Ground.
t	+15v	Auxiliary positive power.

In order to better understand the connector pin-outs, the wiring diagram for this connector is shown graphically in the following figure:

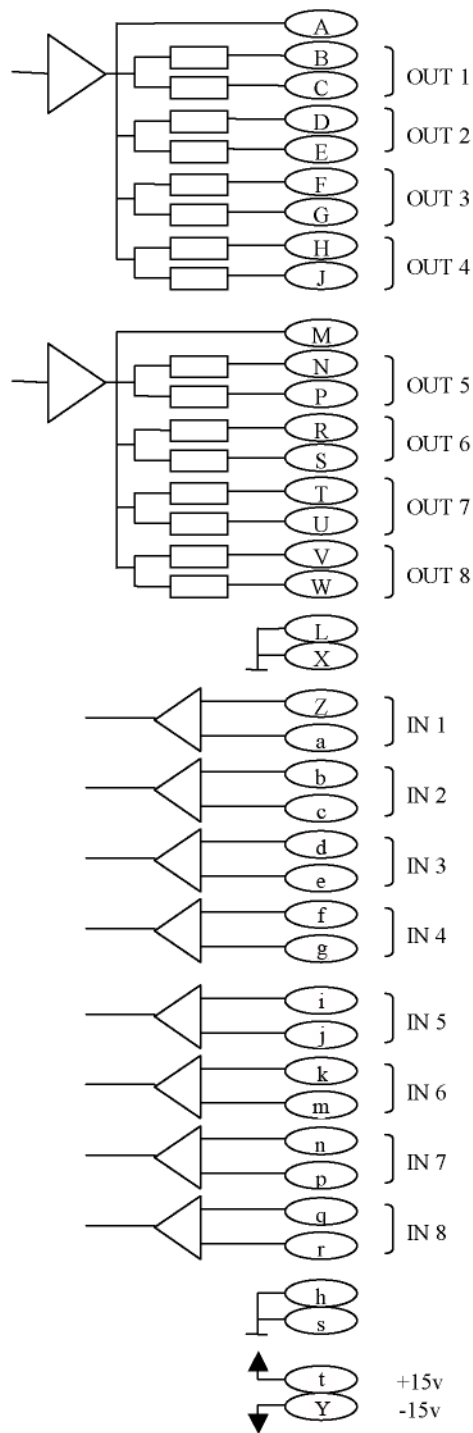
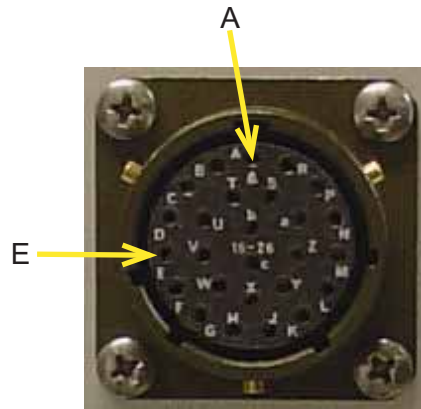

Figure 1 Connections of the coil connector (PROBE).

3.2 REF Connector



Pin	Reference	Manufacturer	Description
1	PT02E16-26S	Amphenol	Panel female connector
2	PT06SE16-26P	Amphenol	Aerial + rear male connector

Pin	Signal	Description
A	G3_BOB1	Direct output 1 of generator 3.
B	G3_BOB11	Output 1 from generator 3 via 100Ω resistance 1.
C	G3_BOB12	Output 1 from generator 3 via 100Ω resistance 2.
D	G4_BOB1.	Direct output 1 of generator 4.
E	G4_BOB11.	Output 1 from generator 4 via 100Ω resistance 1.
F	G4_BOB12.	Output 1 from generator 4 via 100Ω resistance 2.
G	GND	Ground.
H.	G5_BOB1	Direct output 1 of generator 5.
J	G5_BOB11	Output 1 from generator 5 via 100Ω resistance 1.
K	G5_BOB12	Output 1 from generator 5 via 100Ω resistance 2.
L	G6_BOB1.	Direct output 1 of generator 6
M	G6_BOB11	Output 1 from generator 6 via 100Ω resistance 1.
N	G6_BOB12	Output 1 from generator 6 via 100Ω resistance 2.
P	GND	Ground
R	G7_BOB1	Direct output 1 of generator 7.
S	G7_BOB11	Output 1 from generator 7 via 100Ω resistance 1.
T	G7_BOB12	Output 1 from generator 7 via 100Ω resistance 2.
U	G8_BOB1	Direct output 1 of generator 8.
V.	G8_BOB11	Output 1 from generator 8 via 100Ω resistance 1.
W	G8_BOB12	Output 1 from generator 8 via 100Ω resistance 2.

Pin	Signal	Description
X	GND	Ground
Y	—	
Z	—	
a	—	
b	—	
c	—	

In order to better understand the connector pin-outs, the wiring diagram for this connector is shown graphically in the following figure:

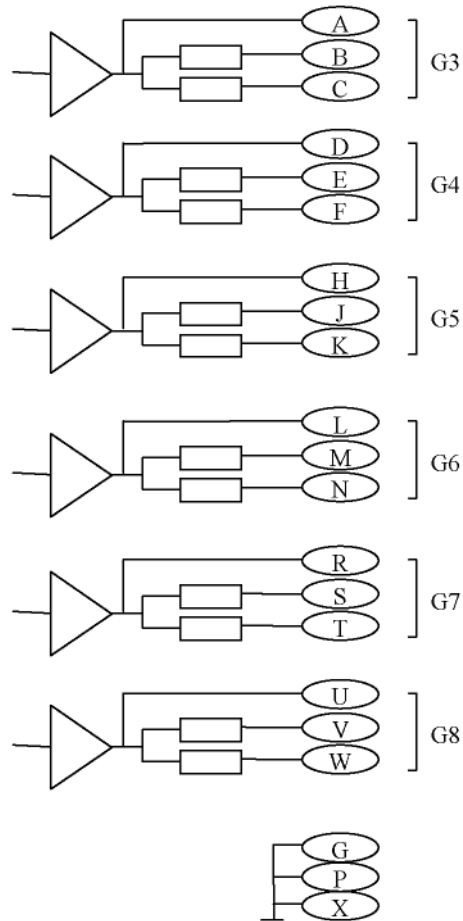
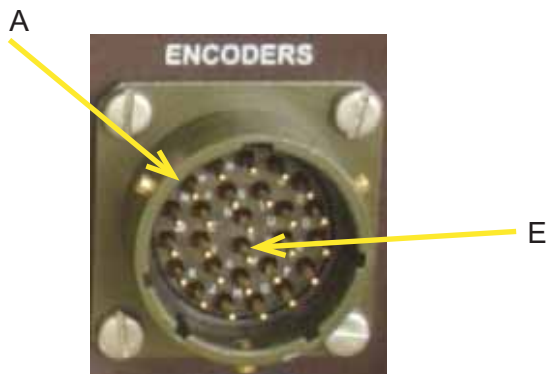

Figure 2 Connections of reference connector (REF).

3.3 Encoders Connection



Pin	Reference	Manufacturer	Description
1	PT02E16-26P	Amphenol	Panel male connector
2	PT06SE16-26S	Amphenol	Aerial + rear female connector

Pin	Signal	Description
A	+5v	Positive power supply voltage.
B	FA1	Phase A of encoder 1 input.
C	FB1	Phase B of encoder 1 input.
D	FC1	Phase C of encoder 1 input.
E	FA2	Phase A of encoder 2 input.
F	FB2.	Phase B of encoder 2 input.
G	FC2	Phase C of encoder 2 input..
H.	FA3	Phase A of encoder 3 input.
J	FB3	Phase B of encoder 3 input.
K	FC3	Phase C of encoder 3 input.
L	FA4.	Phase A of encoder 4 input.
M	FB4	Phase B of encoder 4 input.
N	FC4	Phase C of encoder 4 input.
P	FA5	Phase A of encoder 5 input.
R	FB5	Phase B of encoder 5 input.
S	FC5	Phase C of encoder 5 input.
T	FA6	Phase A of encoder 6 input.
U	FB6	Phase B of encoder 6 input.
V	FC6	Phase C of encoder 6 input.
W	GND	Ground.
X	—	
Y	—	
Z	—	
a	—	
b	—	
c	GND	Ground.

3.4 Digital Connector

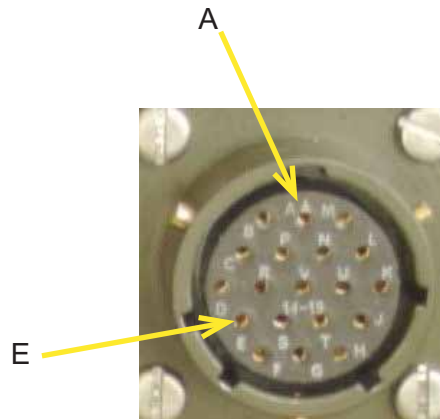

Pin	Reference	Manufacturer	Description
1	PT02E14-19S	Amphenol	Panel female connector
2	PT06SE14-19P	Amphenol	Aerial + rear male connector

Pin	Signal	Description
A	+5v	Positive power supply voltage.
B	IN1	Digital input 1.
C	IN2	Digital input 2
D	IN3	Digital input 3.
E	IN4	Digital input 4.
F	IN5	Digital input 5.
G	IN6	Digital input 6.
H	IN7	Digital input 7.
J	IN8	Digital input 8.
K	GND	Ground.
L	OUT1	Digital output 1.
M	OUT2	Digital output 2
N	OUT3	Digital output 3.
P	OUT4	Digital output 4.
R	OUT5	Digital output 5.
S	OUT6	Digital output 6.
T	OUT7	Digital output 7.
U	OUT8	Digital output 8.
V	+3v3	Positive power supply voltage.

3.5 Analog Connector

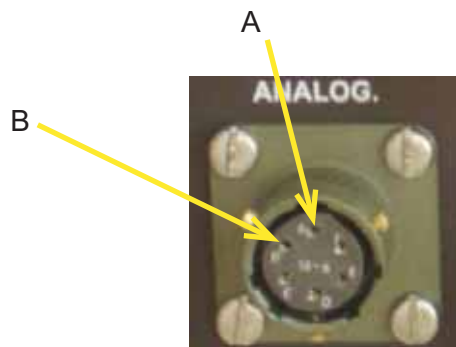

	Reference	Manufacturer	Description
1	PT02E10-6S	Amphenol	Panel female connector
2	PT06SE10-06P	Amphenol	Aerial + rear male connector

Pin	Signal	Description
A	AN_IN1	Analog input 1.
B	AN_IN2	Analog input 2.
C	GND	Ground.
D	AN_OUT1	Analog output 1.
E	AN_OUT2	Analog output 2.
F	GND	Ground.

3.6 Si-Master Connector

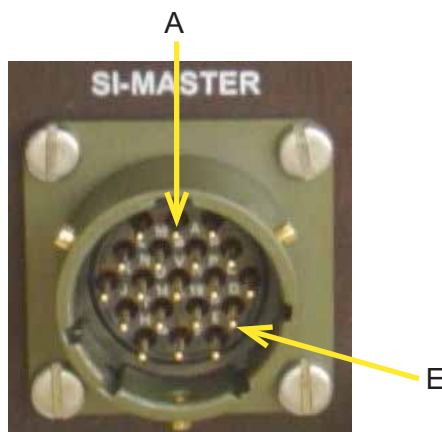

	Reference	Manufacturer	Description
1	PT02E14-19P	Amphenol	Panel male connector
2	PT06SE14-19S	Amphenol	Aerial + rear female connector

Pin	Signal	Description
A	+5v.	Positive power supply voltage.
B	TX232.	RS232 series transmission line.
C	RX232	RS232 series reception line.
D	FO_OUT	Series transmission line for optical fiber.
E	FO_IN	Series reception line for optical fiber.
F	GND.	Ground.
G	STOP1	Stop input 1
H	STOP2	Stop input 2
J	PAUSA1	Pause input 1
K	PAUSA2	Pause input 2.
L	TRIG1	Trigger output 1.
M	TRIG2	Trigger output 2.
N	+5v	Positive power supply voltage.
P	JOY_/CS	/CS line for series communication with Joystick.
R	JOY_CLK	CLK line for series communication with Joystick.
S	JOY_D	D line (data) for series communication with Joystick.
T	—	
U	—	
V	GND	Ground.

3.7 SI-485 Connector



	Reference	Manufacturer	Description
1	DBEE102A051	Fischer	Panel female connector
2	SE102A051-130/4.3-S	Fischer	Aerial male connector

Pin	Signal	Description
1	/B_485	Inverted input of RS485 differential pair.
2	A_485	Direct input of RS485 differential pair.

3.8 Audio Connector

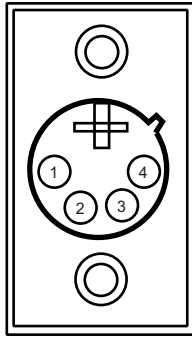

	Reference	Manufacturer	Description
1	NC4MP	Neutrik	Panel male XLR connector
2	NC4FX	Neutrik	Aerial female XLR connector

Pin	Signal	Description
1	MICRO	Input for microphone.
2	GND	Ground.
3	GND	Ground.
4	SPEAKER	Output for loudspeaker.

3.9 Video Connector

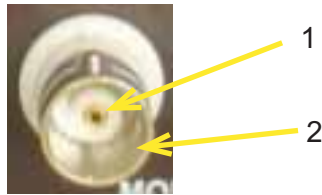

	Description
1	BNC isolated panel female connector
2	Aerial BNC male connector

Pin	Signal	Description
1	VIDEO	Video input.
2	GND	Ground.

3.10 Monitor Connector



	Reference	Manufacturer	Description
1			15-pin sub-D 15 high-density female connector
2			15-pin aerial sub-D high-density male connector.

Pin	Signal	Description
1	Red	Video signal.
2	Green	Video signal.
3	Blue	Video signal.
4	—	
5	GND	Ground.
6	GND	Ground.
7	GND.	Ground.
8	GND.	Ground
9	—	
10	GND.	Ground.
11	—	
12	—	
13	HSYNC.	Horizontal sync.
14	VSYNC	Vertical sync.
15	—	

3.11 Keyboard Connector

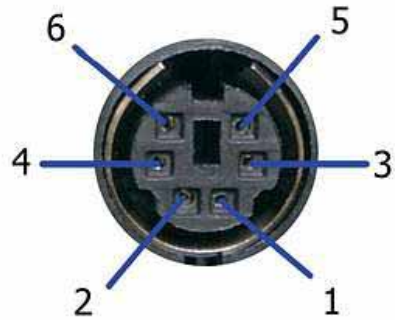

	Reference	Manufacturer	Description
1			6-pin mini-Din female connector.
2			6-pin aerial mini-Din male connector.

Pin	Signal	Description
1	D.	Data line.
2	—	
3	GND.	Ground.
4	+5v	Positive power supply voltage.
5	CLK.	Clock line.
6	—	

3.12 Mouse Connector

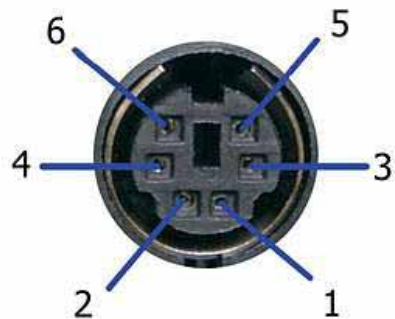

	Reference	Manufacturer	Description
1			6-pin mini-Din female connector.
2			6-pin mini-Din aerial male connector.

Pin	Signal	Description
1	D.	Data line.
2	—	

Pin	Signal	Description
3	GND.	Ground.
4	+5v	Positive power supply voltage.
5	CLK	Clock line.
6	—	

3.13 USB Connector



	Reference	Manufacturer	Description
1			USB A female connector.
2			USB A aerial male connector.

Pin	Signal	Description
1	VBUS	Power supply voltage (+5v).
2	D-	Negative line differential communications pair.
3	D+	Positive line differential communications pair.
4	GND	Ground.

3.14 Ethernet Connector

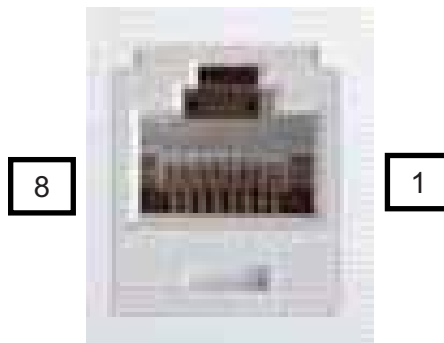

Pin	Reference	Manufacturer	Description
1			RJ45 category 5 female connector.
2			RJ45 category 5 aerial male connector.

Pin	Signal	Description
1	TX+	Positive line of differential transmission pair.
2	TX-	Negative line of differential transmission pair.
3	RX+	Positive line of differential reception pair.
4	—	
5	—	
6	RX-	Negative line of differential reception pair.
7	—	
8	—	

3.15 Power Connector

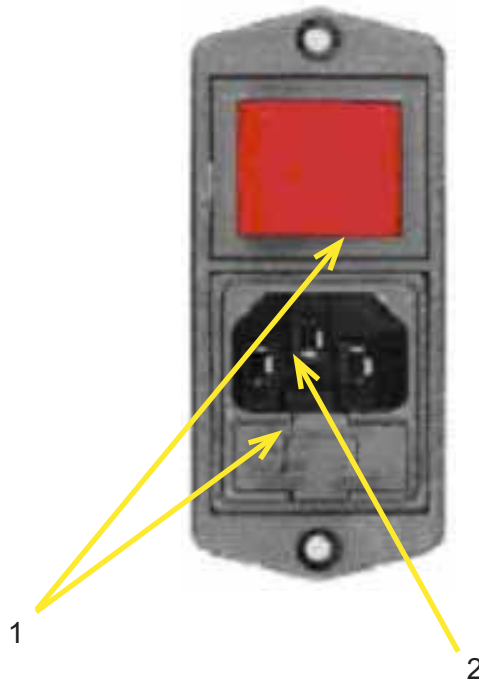

Pin	Reference	Manufacturer	Description
1	BVA01-Z0000-11	Bulgin	IEC network connector with switch, fuse and red neon.
2			IEC network female connector.

Pin	Signal	Description
1	PHASE	110/220 V AC voltage phase.
2	GND	Ground

4

Connections

4.1 Coil Connection

Connection to the coils is accomplished via the PROBE connection located on the equipment panel. Schematically this connector is divided into two sections: transmitters and receivers. All the pins are accessible, so that the final coupling to the coils depends on the connections made at the external adapter between the PROBE connector and the coils

The following figures show a few examples of possible coil connections:

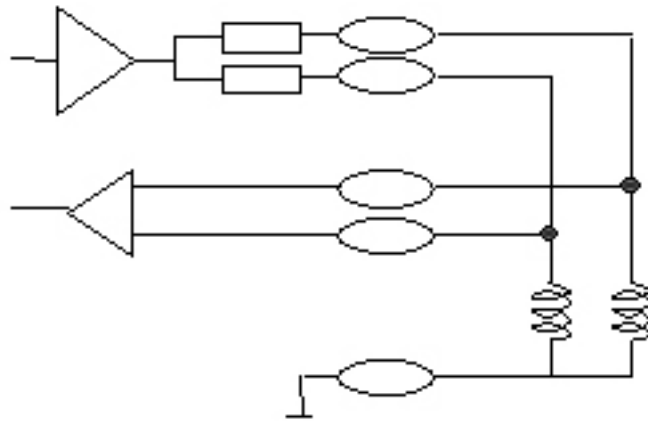

Connection to Differential coil

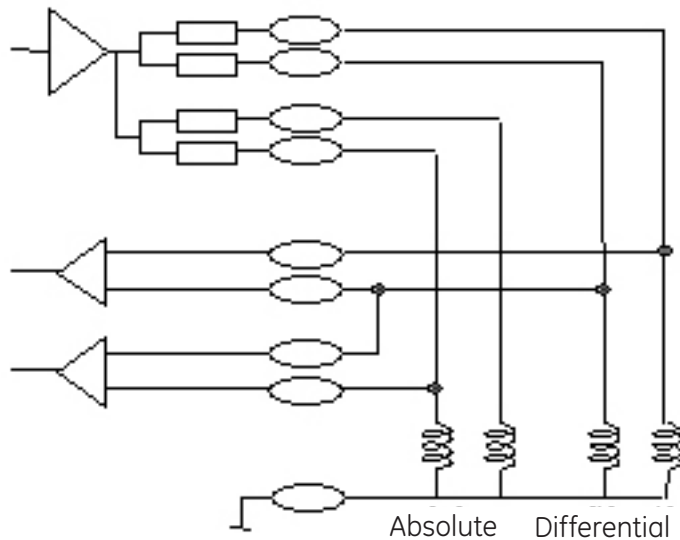

Connection to Differential Absolute coil

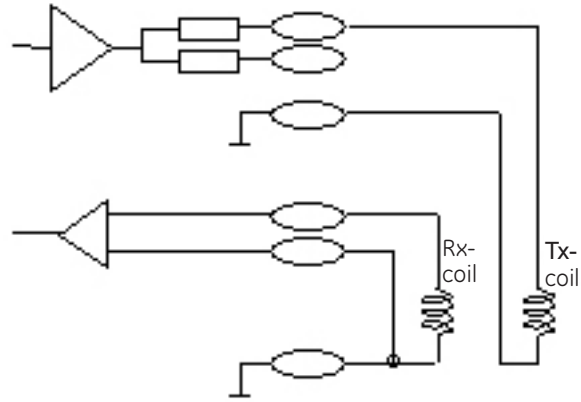

Transmitter (Tx)-Receiver(Rx) Connection

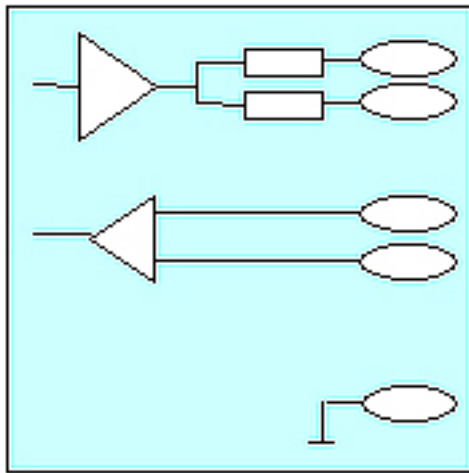

Apollo Equipment

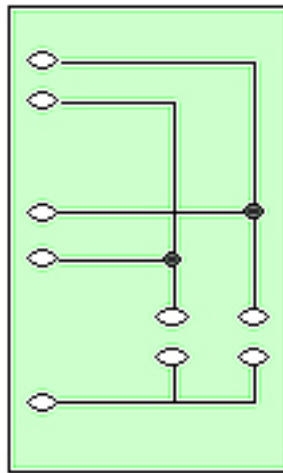

Adapter

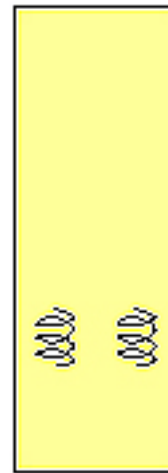

Coils

Connection to Differential Coil

4.2 Equipment Connection

Typical configurations of the Apollo instrument are shown below.

Example 1 Apollo tester in remote mode (connection to computer via Ethernet, no keyboard, no mouse, no monitor attached to the Apollo tester).

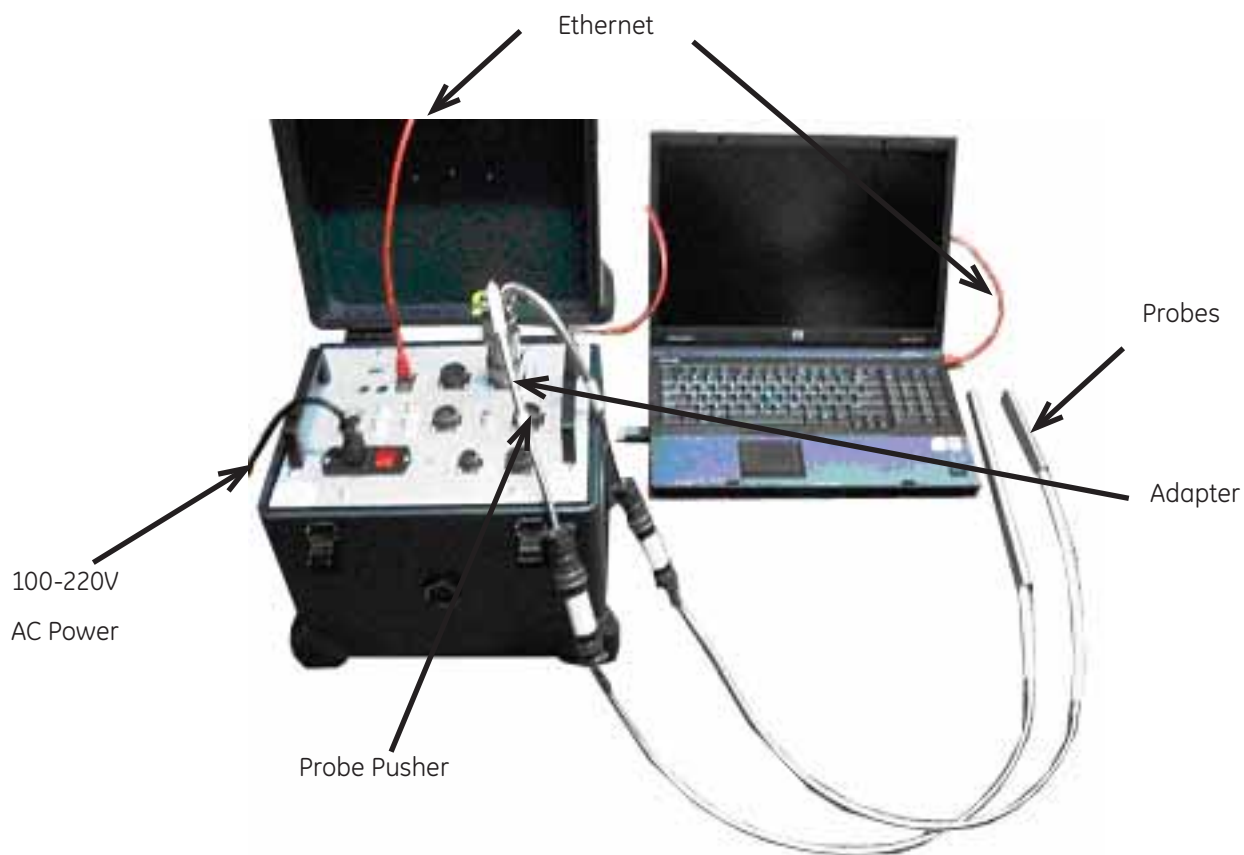

Figure 3 Example of connection of Apollo Tester in remote mode.

5

Maintenance

5.1 Replacing the Fuse

To replace the testers fuse, proceed as follows:

- Turn off the equipment and remove the power cable from the POWER connector.



- Lift the fuse housing with a flat screwdriver.



- Remove the fuse using a flat screwdriver.



- Replace the bad fuse with a new one with the correct voltage and current (See the Specifications Section).
- Lower the fuse housing to its original position.



5.2 Change of Filter

To change the instrument filter, proceed as follows:

- Unscrew and remove the filter plate.
- Remove the filter and replace with a new one.
- Replace the plate and screw in place.

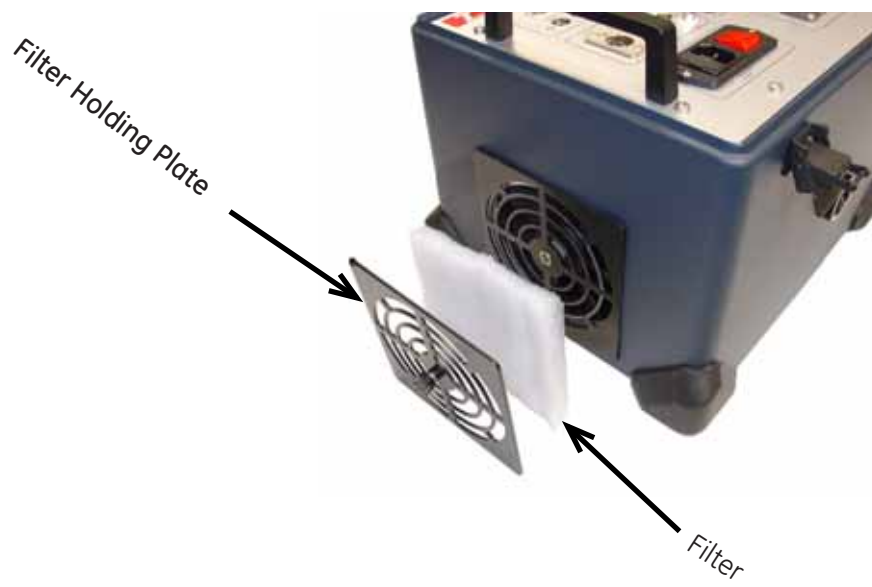

6.1 Trouble Shooting

PROBLEM	ACTION
The ON switch does not light up.	Check that the power cord is connected and in good condition. Check that the fuse is in good condition.
Communications are not established between the equipment and the computer.	Check that the LED indicators light up by performing a sweep. After operating the tester switch it is necessary to wait for the LED indicators to light up. The connection may then be attempted from the PC. Check the Ethernet cable. If there is a HUB Ethernet with various items connected, check that it is active and the connections are correct.
No signals appear on screen.	Check that the sensor is connected to the input configured for the test.
No coordinates appear on screen.	Check that the encoder is connected to the correct input and that it corresponds to the operating mode programmed for it.
The signal always appears saturated.	Check that the adapter is correct.

7

Specifications

7.1 Specifications

SYSTEM		
Start-up time		10 min
Trip modes		Internal, external, synchronized with encoder, software
Acquisition speed		20,000 samples./sec.
Surveillance		Power Supply, Temperature
Ethernet	Speed	10 / 100Mbps
	Length	150m

EMITTERS		
Generators		2
Outputs		8
Modes		Multiplexed, simultaneous injection, multiplexed simultaneous injection
Voltage	Range	0 - 24Vpp
	Resolution	1v
Frequencies	Quantity	32
	Range	10Hz - 10MHz
Impedance	Direct	5 Ω
	With R	105 Ω
Maximum output current		1 A
Measurements		Vout, Iout, Temperature

EC RECEIVERS		
Number of coils		4 (8 with two MRX cards installed)
Number of frequencies		32
Range of frequencies		10Hz - 10MHz
Gain	Modes	Manual, Automatic
	Ranges	0dB - 40dB
	Resolution	1dB

I/O		
Encoders	Number	6 (A,B,C) or 9 (A,B)
	Level	LVTTTL
	Type	Incremental with A, B signals out of phase by 90° or TTL pulse input or level entries. Phase C is admitted.
Digital inputs	Number	8
	Level	LVTTTL
	Modes	Input, Enable acq., Trigger
Digital outputs	Number	8
	Level	LVTTTL
	Modes	Output, Alarm, Trigger
	Width	Programmable (in Trigger mode)
	Active State	H/L programmable
Analog inputs	Number	2
	Range	±15v
	AB	20 KHz
Analog outputs	Number	2
	Range	±10v
	AB	20 KHz

SI-MASTER (optional)			
Modules	32 max		
Communications	RS485	Speed	250 Kb/s
		Length	250 m
	Optical fiber	Speed	250 Kb/s
		Length	1000 m
Inputs	Number	4	
	Level	24 Vmax	
	States	Pull up / pull down configurable	
	Modes	Input, Stop, Pause	
Outputs	Number	2	
	Level	LVTTTL	
	Current	24 mA	
Encoders	Number	8	
	Level	LVTTTL	
	Type	Incremental with A,B signals out of phase by 90° or TTL pulse input or level entries. Phase C is admitted	
Measurements	Vout, Iout, Temperature		

Power Supply	
Voltage	100-220 Vac
Frequency	50-60 Hz
Fuse	250 V, Slow-Blow 5x20mm
Fuse Current Rating	4A at 110 V; 2A at 220V
Power	100 Watts

ENVIRONMENTAL CONDITIONS	
Operating temperature	5°C to 40°C (41°F to 104°F)
Storage temperature	-20°C to 70°C (-4°F to 158°F)
Relative humidity	90% no condensate

CABINET	
Dimensions (width x depth x height)	300 x 250 x 270 mm (11.8 x 9.9 x 10.6 in)
Weight	10 Kg (27 lbs)

REVISIONS	
Revision 0	Initial version

GE Inspection Technologies is an active participant in Europe's Waste Electrical and Electronic

Equipment (WEEE) take-back initiative, directive 2002/96/EC.



The equipment you purchased required the extraction and use of natural resources for its production. It may contain hazardous substances that could impact health and the environment. In order to avoid the dissemination of those substances in our environment and to diminish the pressure on the natural resources, we encourage you to use the appropriate take-back systems. If you need more information on the collection, reuse and recycling systems, please contact your local or regional waste administration.

Visit <http://www.geinspectiontechnologies.com> for take-back instructions and more information about this initiative.

Customer Support Centers

North/South America

50 Industrial Park Road
Lewistown, PA 17044
Tel: 866 243 2638
717 242 0327

Germany

Robert Bosch Str.
50354 Hürth
Tel: +49 2233 601 0

United Kingdom/Ireland

892 Charter Avenue Canley
Coventry CV4 8AF
Tel: +44 845 130 3925

France

68, Chemin des Ormeaux
Limonest 69760
Tel: +33 47 217 9216

E-mail: geit-info@ge.com

Spain

San Maximo, 31, Planta 4A, Nave 6
Madrid 28041
Tel: +34 195 005 990

China

5F, Hongcao Building
421 Hongcao Road
Shanghai 200233
Tel: +86 800 820 1876
+86 21 3414 4620

Japan

7F Medie Corp Bldg. 8
2-4-14 Kichijoji Honcho,
Musashino-shi
Tokyo 180-0004
Tel: +81 442 67 7067

www.geinspectiontechnologies.com

©2008 General Electric Company.
All rights reserved. Specifications subject to change without notice.

Manufactured in USA by GE Sensing & Inspection Technologies

ISO 9001
REGISTERED COMPANY