

ELS-24DC Solarc® Light Source

Operating Manual



Preface

Thank you for purchasing the ELS-24DC Solarc® Hi-Lux Light Source. This product was manufactured for GE Inspection Technologies by Welch Allyn Inc., a technology leader in the design and manufacturer of advanced technology lighting products.

By following the use and care instruction in this guide, you will be rewarded with years of dependable, trouble-free service. Please read these instructions completely before use.

Table of Contents

System Symbol Definitions	2
Warnings and Precautions	3
Avertissements et Precautions	4
System Descriptions	4
System Setup and Operation.....	5
User Maintenance	6
Technical Specifications	7
Troubleshooting Guide	8
Agency Compliance Statements.....	9
Warranty	10
Environmental Compliance.....	11
Contact Information	12

System Symbol Description



Caution: *Refer to User's Manual*



Caution: *Hot Surface*



Replace Fuse as Marked: *Type F, 250V, 2A*



Warning: *High Voltage is Present*



Symbol in Electrical Rating Signifies AC Mains Power



Symbol on Power Switch Indicates Power is ON When Depressed



Symbol on Power Switch Indicates Power is OFF When Depressed



Protective Earth Ground



Equipotential with Ground

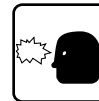

High Intensity Light

Warning and Precautions

**DIRECT VIEWING OF EXITING LIGHT CAN BE HARMFUL!**

The light at the front of the light source and at the tip of a connected fiber-optic bundle is of high intensity and can result in very high temperatures. To minimize the risk of injury, avoid direct viewing of the light or contact with surrounding surfaces. Light includes UV wavelengths which may cause skin or eye irritation from direct exposures exceeding 15 minutes/day.

TO PREVENT TEMPORARY BLINDING

and contact with heated parts, always plug the fiber optic bundle into the light source before turning the power on.

ALWAYS PROVIDE ADEQUATE VENTILATION

to prevent overheating. Do not cover the light source or place the unit within 7.62 cm (3 in.) of a solid object.

DURING OPERATION, THE LAMP SHOULD BE ENCLOSED

within the light source to prevent injury in the occasional circumstance of the lamp shattering.

USE CAUTION WHEN REPLACING LAMP.

Allow lamp to cool. Use only GE Inspection Technologies replacement lamp SPL-240. For optimum performance, avoid handling the bulb or reflector. Fingerprints or other contaminants on the glass may result in performance degradation.

DO NOT SWITCH THE LIGHT SOURCE ON AND OFF IN RAPID SUCCESSION.

Doing so will dramatically shorten lamp life. After turning off, wait 15 seconds before turning on again.

The supplied detachable power cord is the means of disconnect from the power source.

Avertissements et Precautions

L'intensité lumineuse du générateur de lumière et à l'extrémité du guide de lumière, induit une température élevée et une forte luminosité. Pour minimiser les risques de blessures, éviter tout contact direct avec les yeux et la peau.

Afin d'empêcher un aveuglement temporaire et toute brûlure, il est recommandé de connecter le guide de lumière au générateur avant la mise en marche de ce dernier.

Ne pas allumer et éteindre le générateur de lumière successivement. Ceci réduirait considérablement la durée de vie de la lampe. Après l'avoir éteint patienter 10 à 15 seconds avant de le remettre en marche.

ATTENTION:

utiliser une ventilation adéquate pour éviter toute surchauffe du générateur. Si vous le sortez de sa sacoche : ne pas l'envelopper dans un tissu et ne pas le placer à moins de 8 cm de tout objet.

PRECAUTIONS:

à prendre lors du remplacement de la lampe : laisser la lampe refroidir. Utiliser la lampe GE Inspection Technologies Réf: #SPL-240.

System Description

The ELS-24DC Hi-Lux Light Source provides high-quality, white light for industrial borescope and fiberscope inspections. It incorporates a patented and field-proven lamp technology that has much greater efficiency than halogen or xenon lamps when transferring light into a small fiber bundle, such as that found in borescopes and fiberscopes.

This greater efficiency allows the lamp to run at only 24W, which then enables a small and lightweight light source design. The high efficiency also enables the light source to provide high intensity light without getting very hot, which is an advantage in user safety.

System Setup and Operation

1. With the power switch in the OFF position (**●**), plug in the light source to an AC outlet, using the AC adapter, or 12V PowerBar™ battery using the battery power cable (refer to XA207S-LSMAN for setup instructions).
2. Turn the Light Intensity Control Lever to the minimum position (**Figure 1**). Plug the fiber-optic bundle into the light port and connect the opposite end to the equipment being used.
3. Turn the power switch ON position (**I**). The lamp will take 10-15 seconds to complete the warm-up cycle.
4. Set the light intensity to the desired level (**Figure 1**).

Note: Turn OFF PowerBar battery and disconnect PowerBar battery cable from the ELS-24DC light source unit when not in use or during transport.

Note: Do not restart the light source immediately after shutting it off - it may fail to light. If this occurs, turn the power off and wait 10-15 seconds before turning the unit back on.

Note: For proper lamp performance, make sure the fiber-optic bundle is fully inserted at all times.

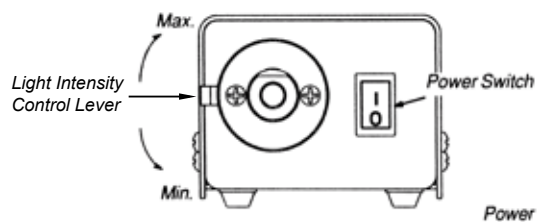

Figure 1 Front View

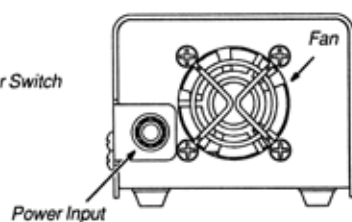

Figure 2 Back View

User Maintenance

Lamp Replacement

Allow lamp to cool before replacing. Use replacement lamp SPL-240

Caution



Hot Surface

1. Turn the light source off and unplug the power cord.
2. Remove the four thumb-screws on the sides and lift off the top cover to expose the lamp (**Figure 3**).
3. Remove the lamp by pulling it back against the retaining spring and then up (**Figure 4**). Pull to disconnect lamp from harness connector and discard lamp.
4. Connect the new lamp to the harness. Use lamp SPL-240. Pull retainer spring back and slide new lamp into lamp cavity ensuring the alignment pin fits into bottom slot of unit housing. When in proper position, lamp should be at slight incline with connector just above housing floor. Pin alignment can be checked by turning light source upside down and viewing through window in bottom housing.
5. Replace the cover and secure with four screws. Reconnect power cord.

Note: When replacing lamp take care not to touch the bulb or interior reflective surface of the lamp. Skin oils on the lamp will cause premature lamp failure. Hold lamp by the outside of the reflector or the connector only. Remove any grease or fingerprints with a clean cotton swab moistened with alcohol. Do not leave any lint on the lamp.

Remove screws and lift cover.

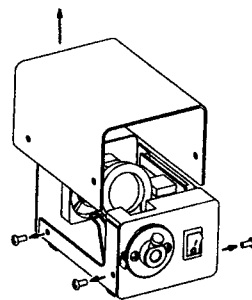

Figure 3

Pull lamp back and up.

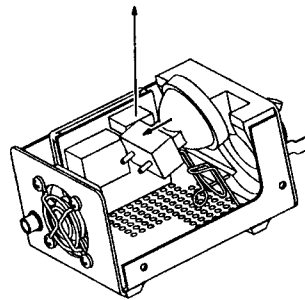

Figure 4

Technical Specifications

Power Ratings

Light Source Input	12VDC, 2.6A DC
AC Adapter Input	100-240VAC, 50/60 Hz, 1.6A max, Phihong model PSS-45W-120 (GE Inspection Technologies Part ELS-24DCA) recommended

Physical

Dimensions	11.43 x 8.38 x 8.38 cm (4.5 x 3.3 x 3.3 in.)
Weight	0.7 kg (1.6 lbs.)

Illumination System

Lamp	Solarc® Metal-Halide, 24W, 60V, Part SPL-240
Color Temperature	5500K
Median Lamp Life	350 hours
Intensity Control	Manual shutter
Light Guide Interface	ACMI (Accepts Olympus cable using ELS-24-0 adaptor, sold separately).

Environment

Operating

Temperature	0°C to 38°C (32°F to 100°F)
Humidity	0 to 95% relative humidity

Storage

Temperature	-23°C to 60°C (-10°F to 140°F)
Humidity	30 to 75% relative humidity

Equipment Classifications:

Class 1, Type B, Continuous Operation, Pollution Degree 2

Agency Certifications:

ETL, CE, FCC Part 15 Class A
EN61010-1, EN50081-1, EN50081-2
Certified to: CAN/USA STD C22.2 No. 61010-1
Conforms to: UL STD 61010-1

Troubleshooting Guide

SYMPTOM	PROBABLE CAUSE	SOLUTION
<ul style="list-style-type: none"> Lamp is not illuminating and fan <i>is</i> operating. 	<ul style="list-style-type: none"> Lamp was not given adequate time to “cool down” before restarting. 	<ul style="list-style-type: none"> Turn unit off and wait 10 - 20 seconds before turning back on.
	<ul style="list-style-type: none"> Light Source has overheated. 	<ul style="list-style-type: none"> Verify environmental temperature does not exceed specifications and allow to cool down for 10 - 20 minutes. Check to ensure vents and fan exhaust are not obstructed.
	<ul style="list-style-type: none"> Lamp has burned out. 	<ul style="list-style-type: none"> Replace lamp in accordance with instructions in the USER MAINTENANCE section of this manual. Use only GE Inspection Technologies replacement lamp part number SPL-240.

SYMPTOM	PROBABLE CAUSE	SOLUTION
<ul style="list-style-type: none"> Lamp is not illuminating and fan <i>is NOT</i> operating... 	<ul style="list-style-type: none"> Power cord not securely connected to light source or AC/DC source. 	<ul style="list-style-type: none"> Check for secure connections.
	<ul style="list-style-type: none"> AC/DC source is not active. 	<ul style="list-style-type: none"> Use another power source or restore power to the current source.
	<ul style="list-style-type: none"> Power cord is damaged (may cause intermittent operation). 	<ul style="list-style-type: none"> Replace power cord.
	<ul style="list-style-type: none"> Light source power switch is not turned on. 	<ul style="list-style-type: none"> Turn switch to the (I) position.

*If the above suggestions do not solve the problem, call GE Inspection Technologies Service Center listed on the back of this manual. **DO NOT ATTEMPT DISASSEMBLY! THERE ARE NO USER SERVICEABLE COMPONENTS OTHER THAN LAMP.***

Agency Compliance Statements

This device complies with part 15 of the FCC Rules. Operation is subject to the following two conditions: (1) This device may not cause harmful interference, and (2) this device must accept any interference received, including interference that may cause undesired operation.

FCC Class A Compliance Statement

This equipment has been tested and found to comply with the limits for a Class A digital device, pursuant to part 15 of the FCC Rules. These limits are designed to provide reasonable protection against harmful interference when the equipment is operated in a commercial environment. This equipment generates, uses, and can radiate radio frequency energy and, if not installed and used in accordance with the instruction manual, may cause harmful interference to radio communications. Operation of this equipment in a residential area is likely to cause harmful interference, in which case the user will be required to correct the interference at his own expense.

Caution: Any changes or modifications made to this device that are not expressly approved by GE Inspection Technologies may void the user's authority to operate the equipment.

Note: To maintain compliance with FCC Rules and Regulations, cables connected to this device must be shielded cables, in which the cable shield wire(s) have been grounded (tied) to the connector shell.

Canadian Notice

This equipment does not exceed the Class A limits for radio noise emissions as described in the Radio Interference Regulations of the Canadian Department of Communications.

Le present appareil numerique n'emet pas de bruits radioelectriques depassant les limites applicables aux appareils numeriques de la classe A prescrites dans le Reglement sur le brouillage radioelectrique edicte par le ministere des Communications du Canada.

Warranty

GE Inspection Technologies warrants the ELS-24DC Light Source to be free of defects in material and workmanship and to perform in accordance with the manufacturer's specifications when subject to normal use and service for a period of one year from the date of purchase. GE Inspection Technologies will either repair or replace components found to be defective or at variance from the manufacturer's specifications within this time at no cost to the customer. It shall be the purchaser's responsibility to return the instrument to the authorized service center.

This warranty does not apply to the lamp, or cover instrument breakage or failure due to tampering, misuse, neglect, accidents, improper installation, modification, shipping, or to improper maintenance, service, and cleaning procedures. This warranty is also void if the instrument is not used in accordance with the manufacturer's recommendations or if required service is performed by anyone other than an GE Inspection Technologies authorized agent. No other express or implied warranty is given.

Environmental Compliance

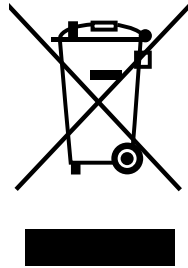

The equipment that you bought has required the extraction and use of natural resources for its production. It may contain hazardous substances that could impact health and the environment.

In order to avoid the dissemination of those substances in our environment and to diminish the pressure on the natural resources, we encourage you to use the appropriate take-back systems. Those systems will reuse or recycle most of the materials of your end life equipment in a sound way.

The crossed-out wheeled bin symbol invites you to use those systems.

If you need more information on the collection, reuse and recycling systems, please contact your local or regional waste administration.

Visit www.ge.com/inspectiontechnologies for take-back instructions and more information about this initiative.

Service Contact Information

USA

GE Inspection Technologies
Product Service Dept.
4619 Jordan Road North Dock
Skaneateles Falls, NY 13153

Tel: 315-685-4142
Fax: 315-685-2920
Email: rvi-service@ge.com

Germany

GE Inspection Technologies
Lotzenäcker 4
72379 Hechigen

Tel: +49-7471-9882 20
Fax: +49 7471-9882 30
Email: rvi-infoeuropa@ge.com

Hong Kong

GE Inspection Technologies
Unit 1602, 16/F Sing Pao Building
101 King's Road
North Point, Hong Kong

Tel: +852-2877-0801
Fax: +852-2877-0868
Email: rvi-infohongkong@ge.com

Customer Support Centers

North/South America

4619 Jordan Road
Skaneateles Falls, NY 13153
Tel: 888-332-3848
315-685-4142
Email: rvi-info@ge.com

Europe

Lotzenäcker 4
72379 Hechingen
Germany
Tel: +49 (0) 7471 9882 0
Email: rvi-infoeuropa@ge.com

Asia/Pacific

Unit 1602, 16/F Sing Pao Building
101 King's Road
North Point
Hong Kong
Tel: +852 2877 0801
Email: rvi-infohongkong@ge.com

www.ge.com/inspectiontechnologies

©2007 General Electric Company.
PowerBar is a trademark of GE Inspection Technologies, LP.
Solarc is a registered trademark of Welch Allyn, Inc.

Manufactured in USA by GE Inspection Technologies

ISO 9001
REGISTERED COMPANY